

Advanced Solutions for Energy Actual Challenges

Keysight Technologies

2018.07.05

Adolfo del Solar



Power Grid Evolution

Conventional grid operation is simple: one-way power flow from a centralized utility to consumer...but today's power grid is evolving

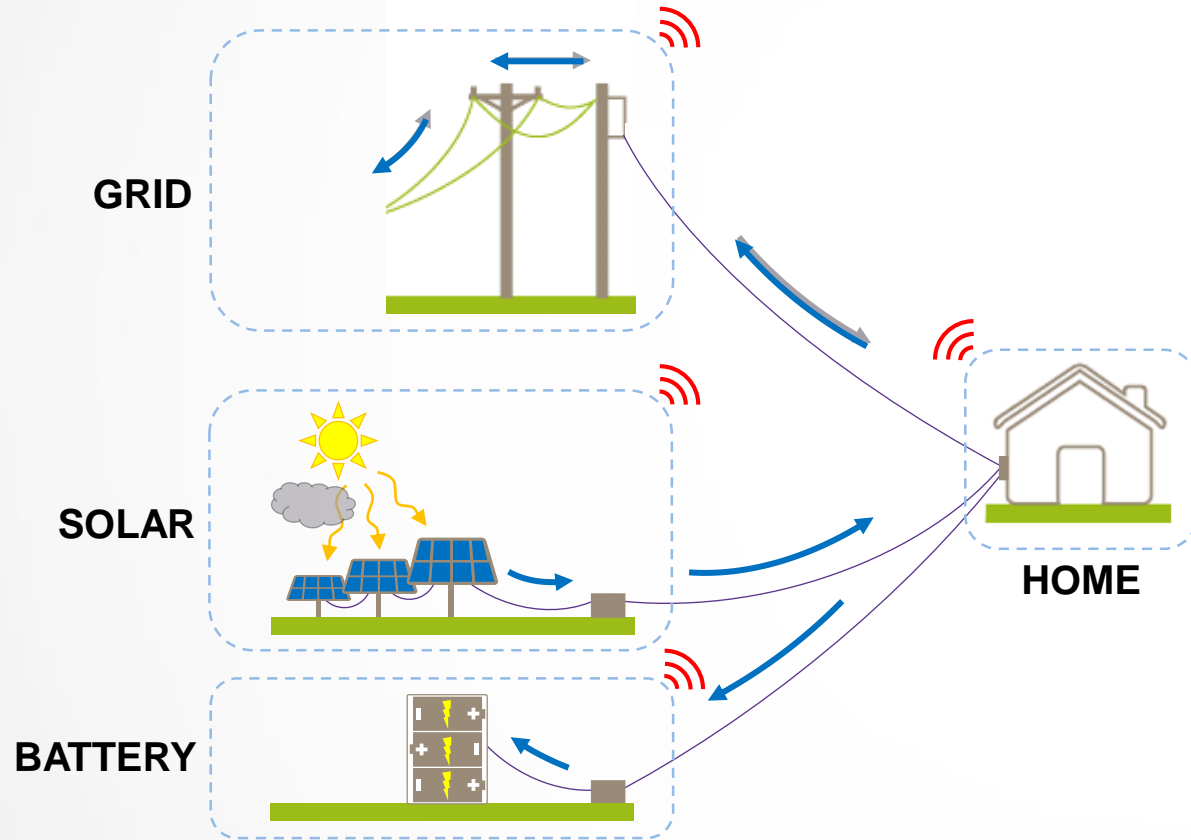

With distributed energy resources (DERs), consumers might also get their electricity from local renewables like grid-tied solar

As the amount of solar power generation goes down, the consumer will require more power from the grid

If the amount of solar power generated exceeds the demand of the consumer, the excess power can be delivered back to the grid

When grid-tied battery banks are added, we can instead use excess solar power to charge the batteries for later utilization

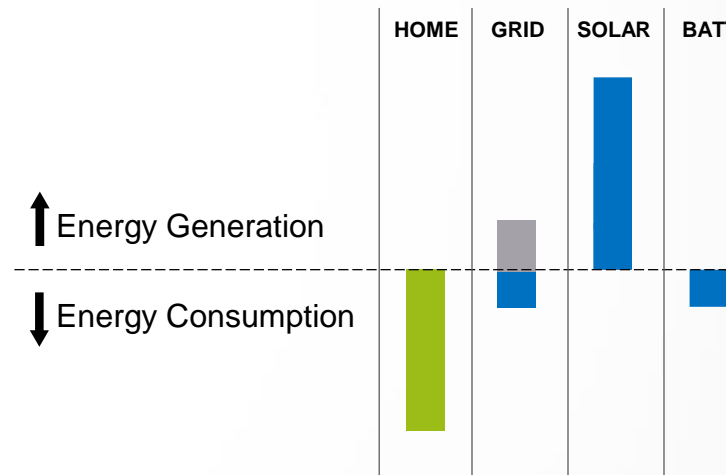

With the interconnection of these various energy resources, we can select which power sources to use and when to use them. Coordinated bi-directional power flow enables optimization of all available energy resources

Power Grid Evolution

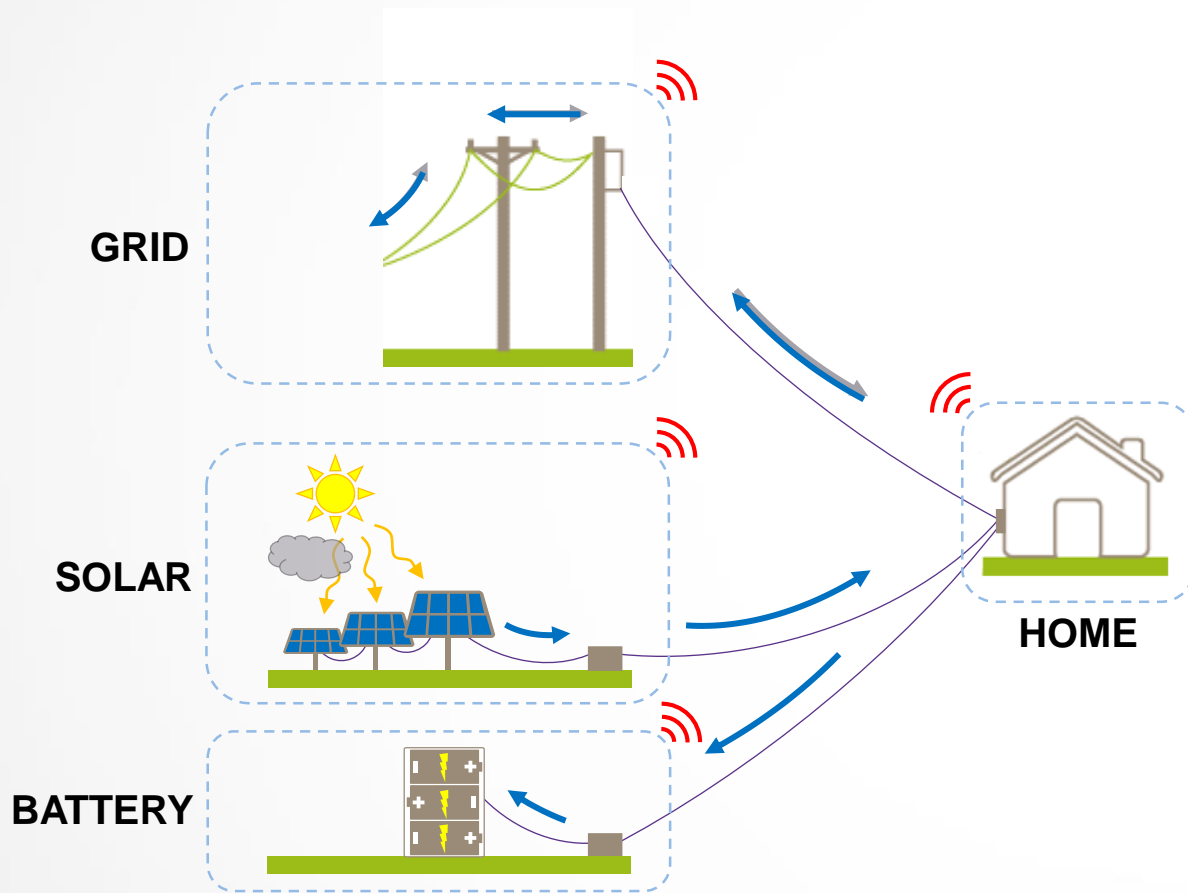

But how does the system know when to deliver PV power to the batteries vs to the grid?

How do we know power flow is being optimized to reduce electricity costs and increase reliability?

How can we be confident these operations are being carried out safely?

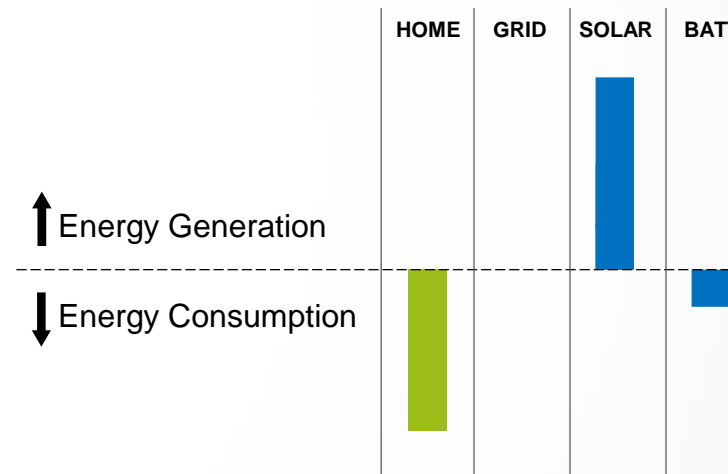

Intelligent monitoring, digital communication, and bi-directional power flow control is needed to enable real-time energy management and optimization... THIS IS WHAT CREATES THE “SMART GRID”

The Smart Grid

- The Power Conversion System (PCS) has evolved to function not only as the physical Gateway for a DER's connection to the grid, but also as the brain for communicating across the network and coordinating with its surroundings to provide specific power flow functions for increased efficiency, safety, reliability, and sustainability.
- The burden of enabling these functions falls on the PCS manufacturers

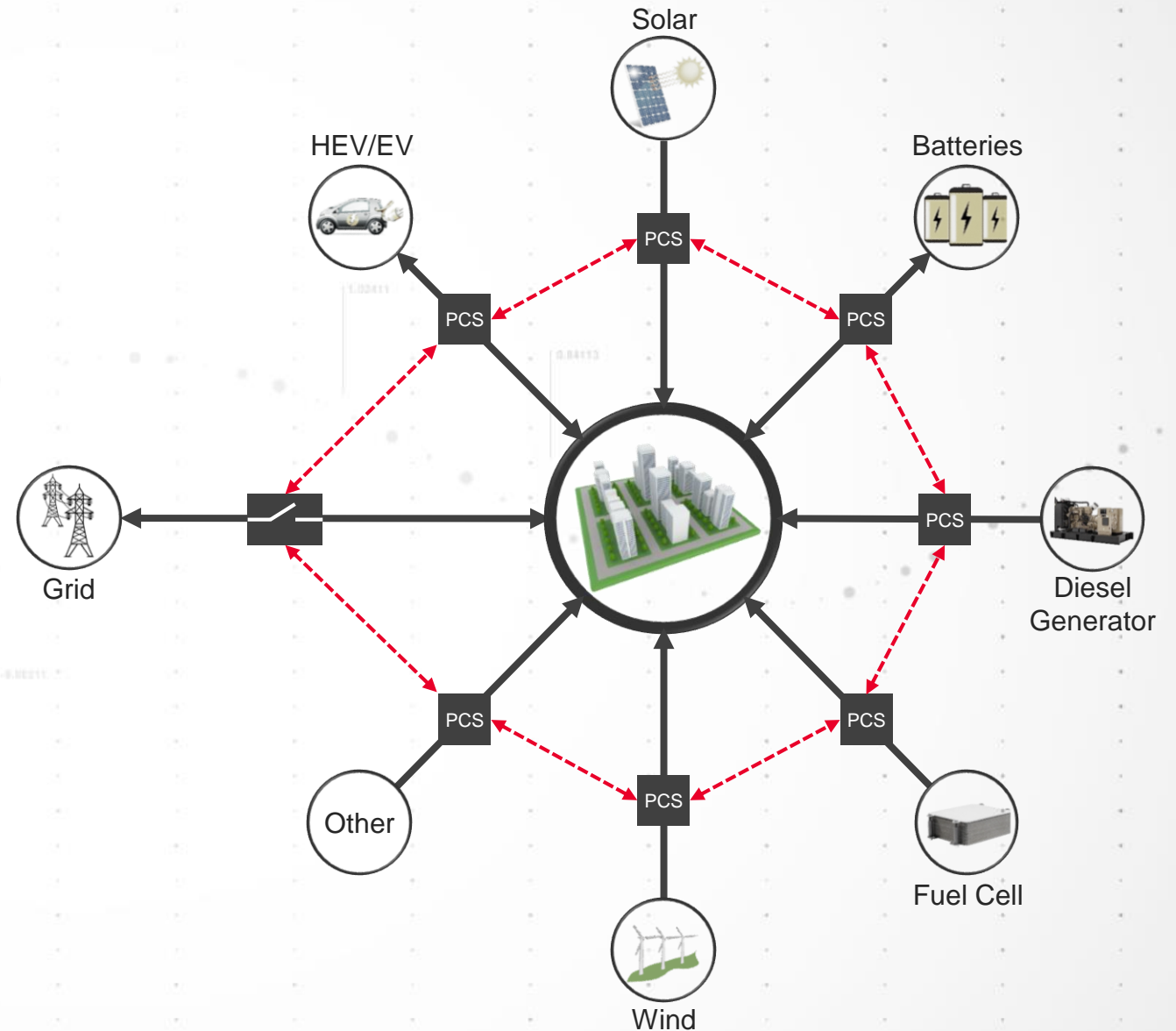

Solar Energy

Sunlight Converted to Electricity

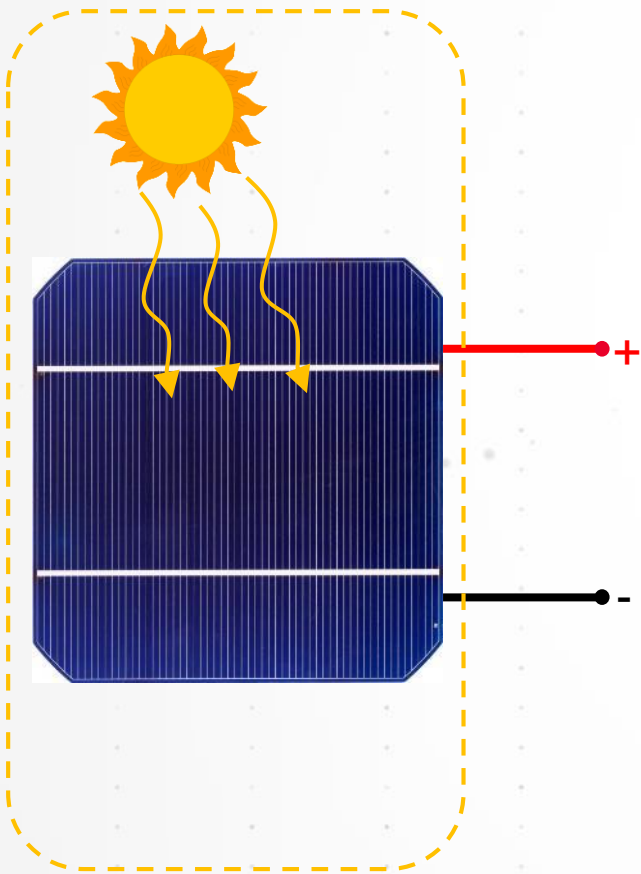

Single Solar PV Cell

- Constructed of semiconductor materials
- Generates electricity when exposed to sunlight; referred to as the “photovoltaic (PV) effect”
- DC output exhibits specific relationship between voltage and current called the “I-V curve”
- I-V curve depends on “solar irradiance” (sun intensity) and cell temperature

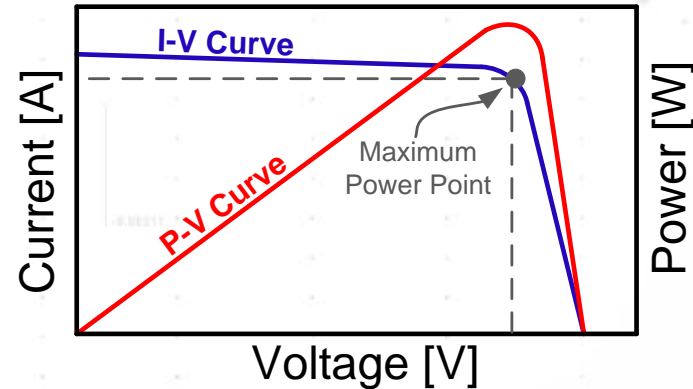

Solar Energy

Sunlight Converted to Electricity

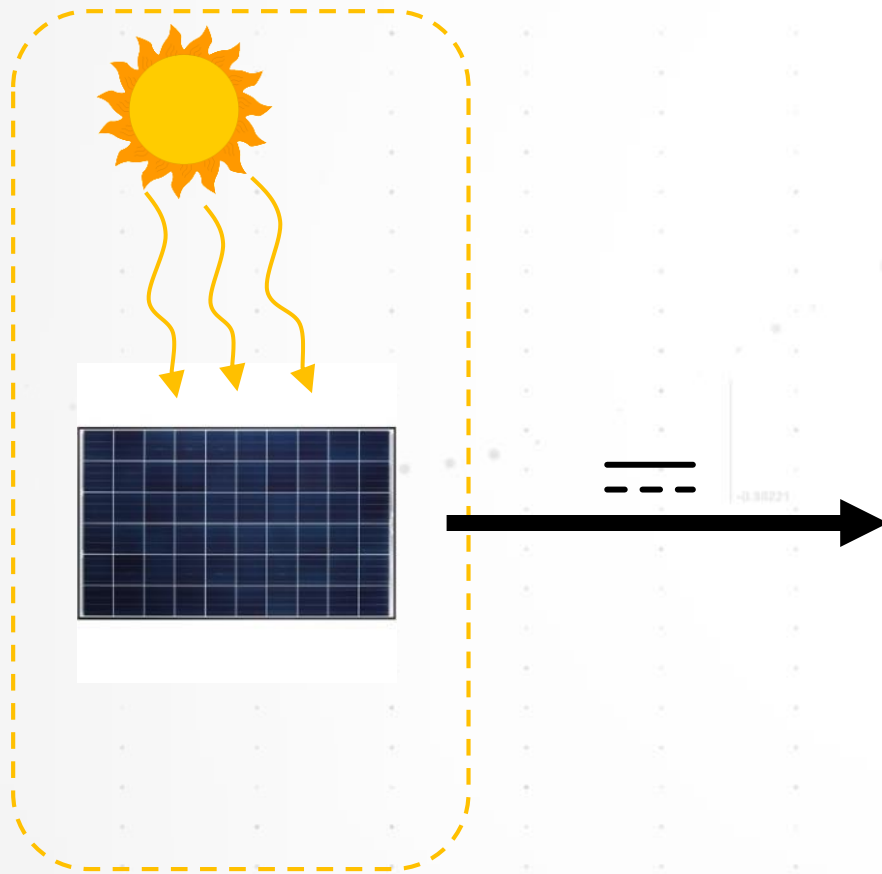

Solar PV Module/Panel

- Constructed by connecting multiple solar cells in series/parallel to boost the overall voltage/current output
- Typically produces ~200W-350W under nominal solar irradiance
- Individual PV modules can similarly be connected in series/parallel to create a “PV array”

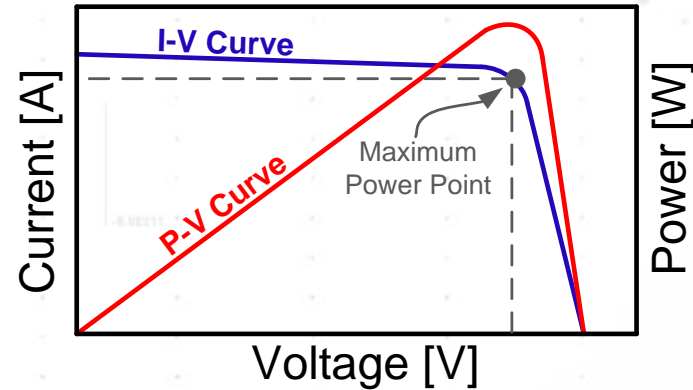

Solar Energy

Sunlight Converted to Electricity

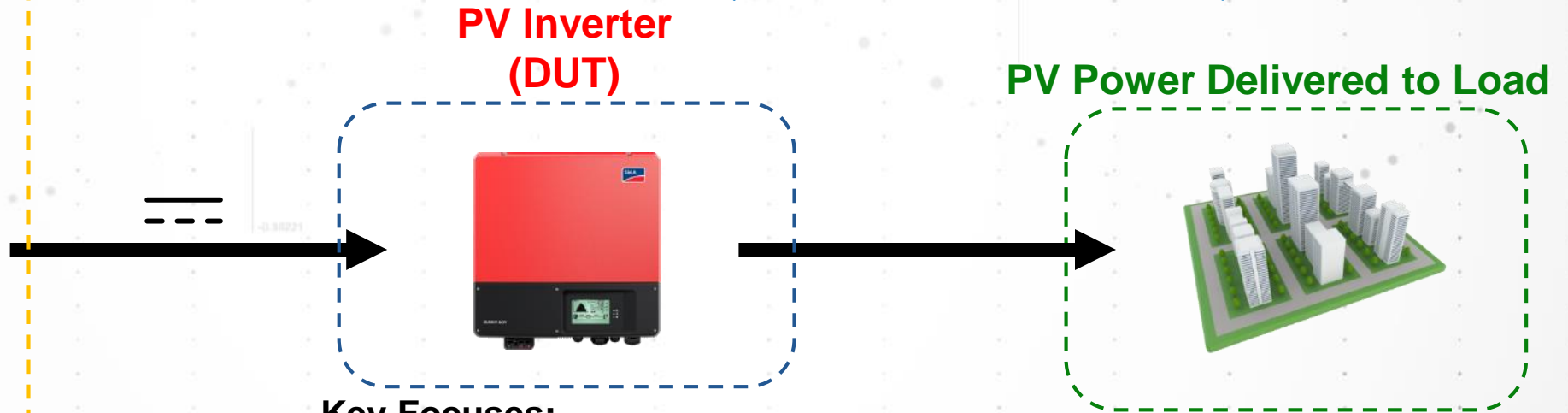
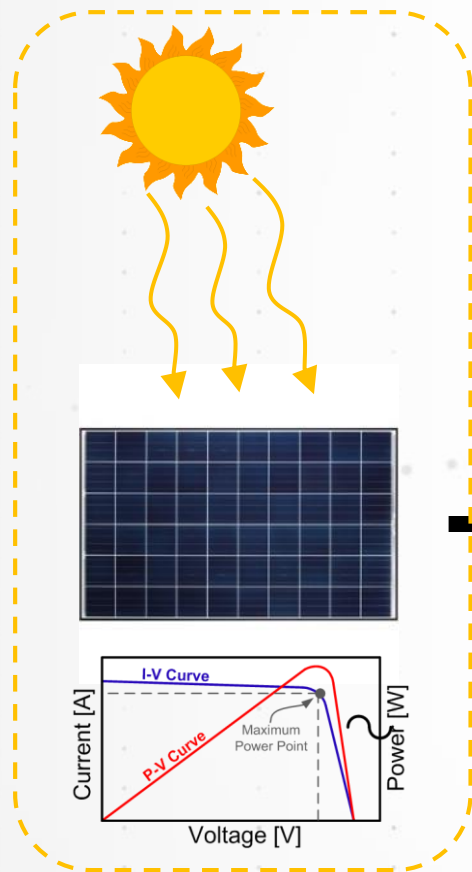

Key Focuses:

- Maximum Power Point Tracking Accuracy (MPPT)
- DC:AC Conversion Efficiency
- Safety Standards Compliance
- Grid Interconnection/Interoperability

Maximizing PV Power Generation

- A PV array's I-V curve is constantly changing due to variations in environmental conditions (i.e., irradiance, temperature)
- As I-V curve changes, so does the load characteristic required for extracting maximum power (Ohm's Law: $V=I \cdot R$)
- Control is needed to ensure PV output is maximized for any given environmental condition

Power Conditioning

- Power conditioning is necessary to invert PV output from DC to AC power at utility frequency (50/60Hz)
- This allows PV output to be distributed to grid-connected loads (i.e., residences, businesses, etc...)

Maximum Power Point Track (MPPT) Efficiency

PV INVERTER TESTING

- **MPPT:**
 - Continuously samples PV system output and adjusts PV inverter input to match resistance of the maximum power point (MPP) for a given I-V curve
- **DRIVING FACTOR:**
 - Higher MPPT accuracy = higher lifetime energy production
- **KEY TEST CHALLENGES:**
 - Higher operating voltages (1,500VDC)
 - Battery of regional test standards/requirements
 - Partial shading conditions

- Sandia Protocol; CEC
- NB/T 32004
- EN 50530
- IEC 61683

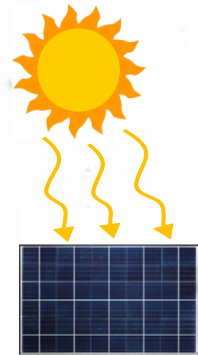

1500VDC

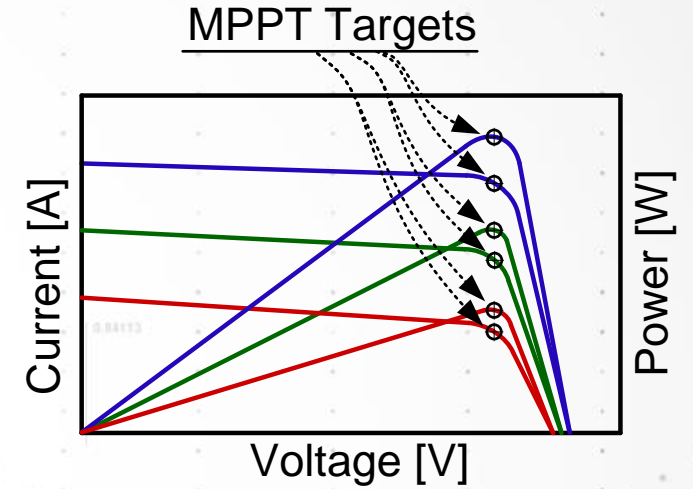
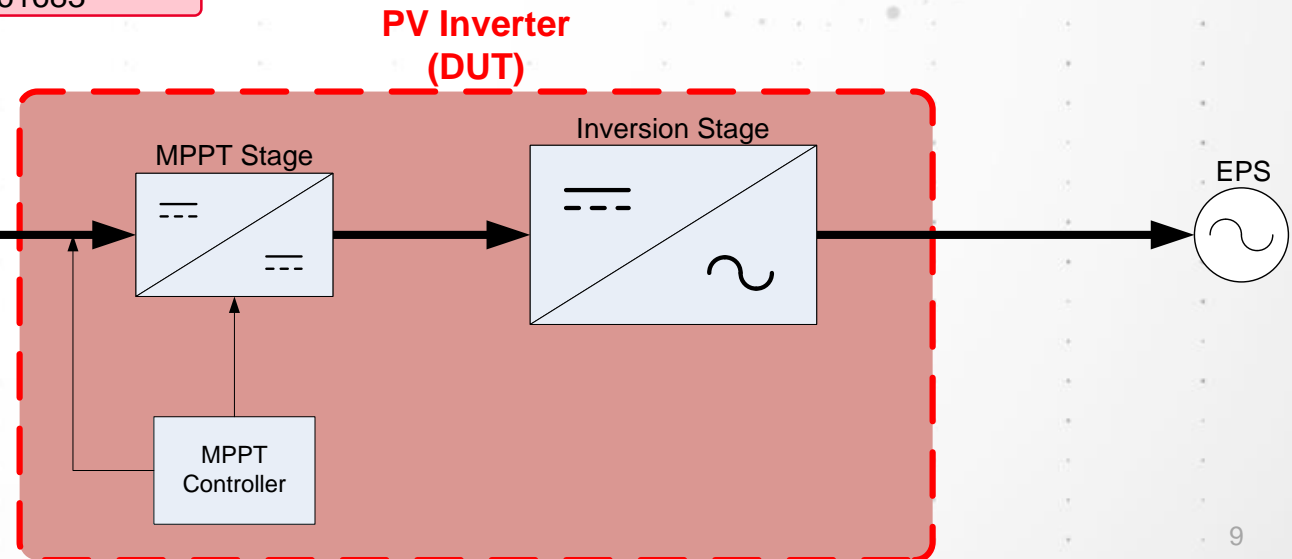

Total Conversion Efficiency

- **Total Conversion Efficiency:**
 - Percentage of available DC power converted to AC power; defines overall performance/competitiveness of PV inverter
- **DRIVING FACTOR:**
 - Lower LCOE = faster ROI
- **KEY TEST CHALLENGES**
 - Higher operating voltages (1,500VDC)
 - Measurement accuracy (>98% efficiency)
 - Battery of regional test standards/requirements
 - Multiple MPPT inputs in a single inverter
 - Quantity/quality of data; post-test data analysis requirements

$$\text{LCOE} = \frac{\text{Total Lifetime Costs}}{\text{Total Energy Production}}$$

higher inverter efficiency = higher total energy production = lower LCOE

- Sandia Protocol; CEC
- NB/T 32004
- EN 50530
- IEC 61683

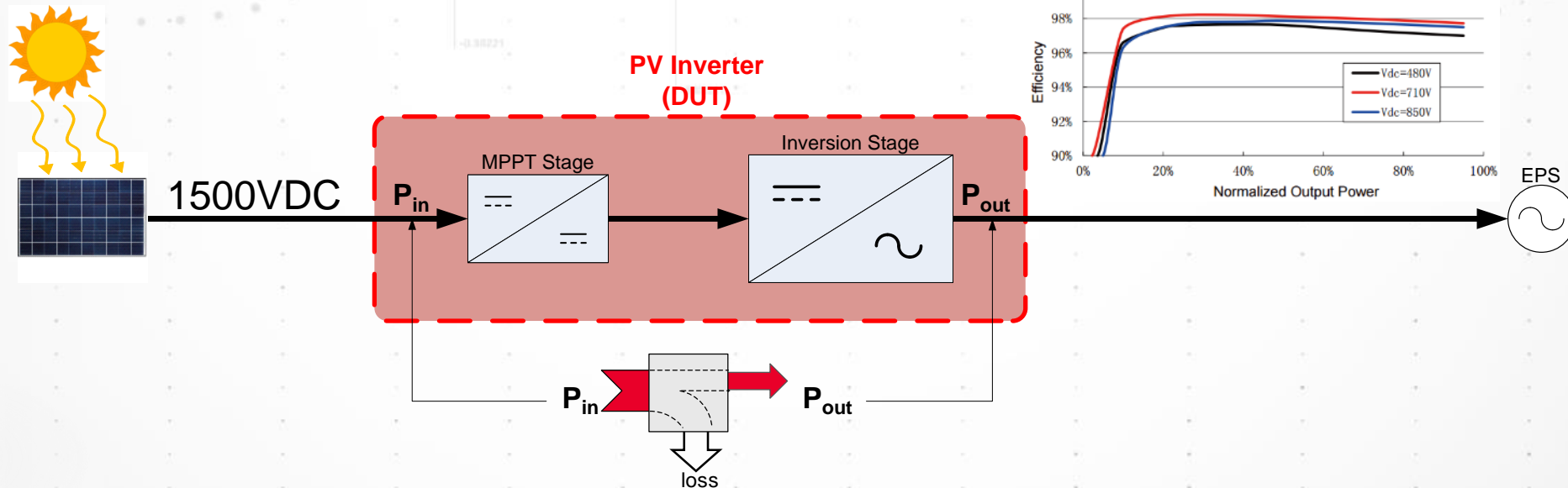

Keysight Photovoltaic Array Simulation Solution

The world's first single-box, 1500V photovoltaic inverter test solution with intuitive software

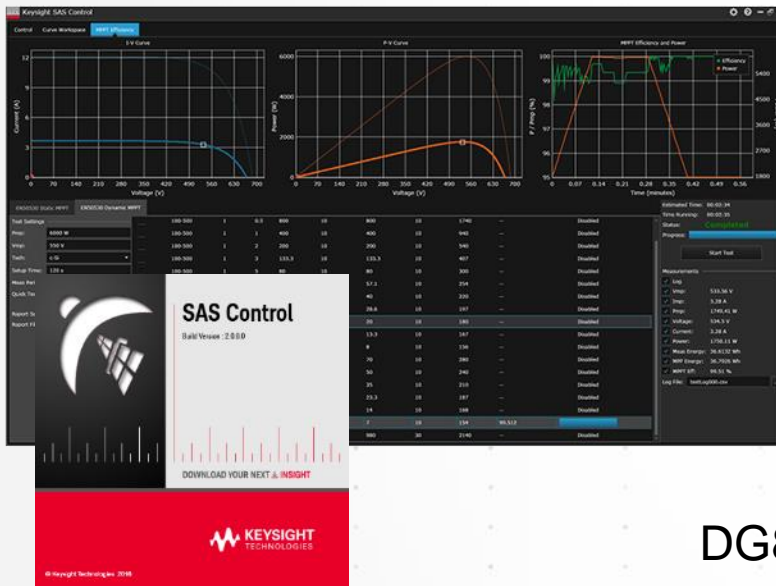

DG8901A

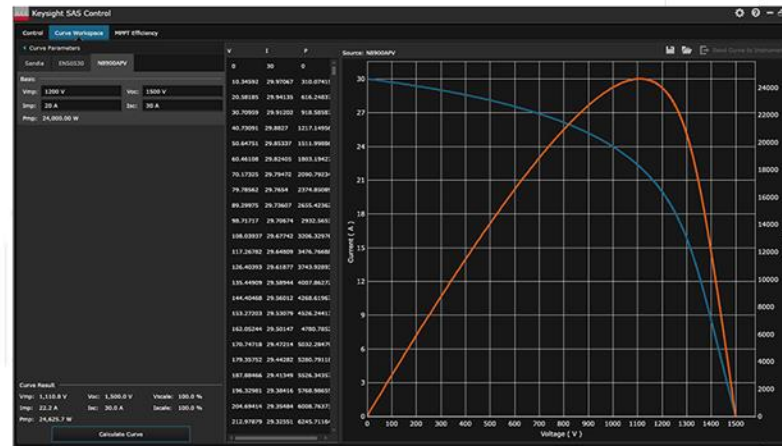

N8900APV

Keysight's PV Simulation Solution

KEY TEST CHALLENGES:

- ✓ Higher operating voltages (1,500VDC)
- Battery of regional test standards/requirements
- Partial shading conditions

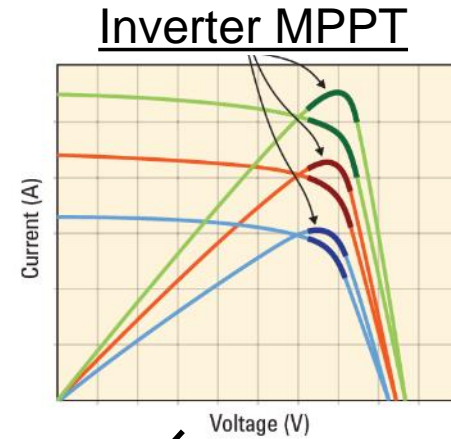
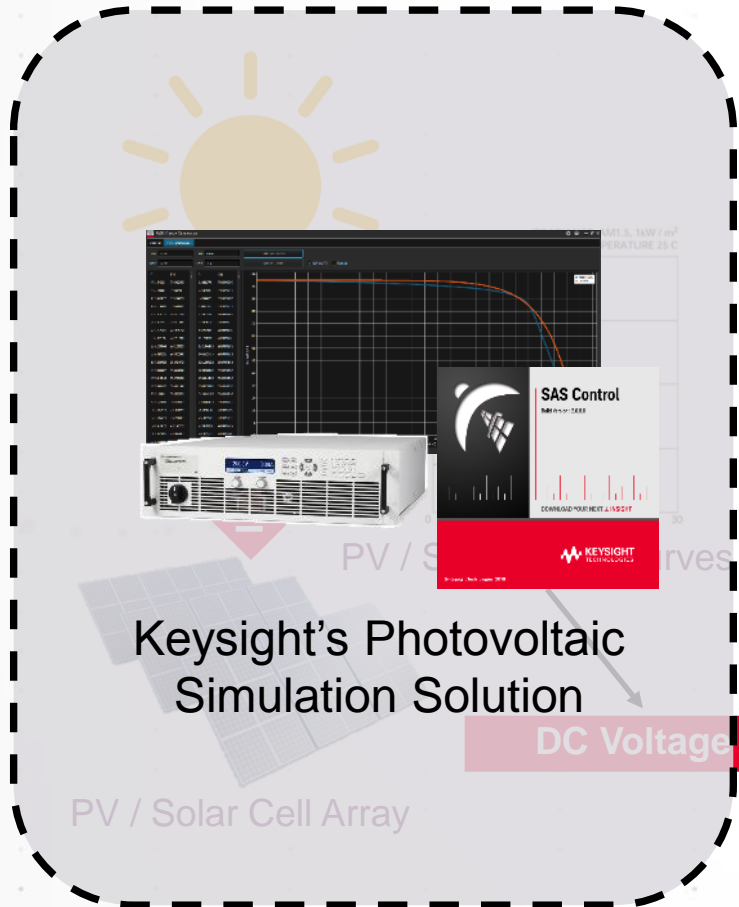

Maximum
Power
Point
Tracking

Proprietary Algorithms



PV / Solar Inverter
(DC → AC)

AC Voltage

- Grid
- Home
- ...

Benefits of using a Photovoltaic Simulator

EASIER THAN SOLAR ARRAYS

In a perfect world, engineers would use actual solar arrays to do their testing. However...

Solar arrays are:

- Very large
- Very expensive
- At the will of the weather

This does not work very well in the environment where solar inverters are tested

A Photovoltaic (PV) Simulator is the right choice for test

A PV Simulator is:

- Smaller
- Less expensive
- Able to program output corresponding to varying weather conditions
- Backed by a Keysight warranty

There is also software to make testing easier

EN50530 Testing

DYNAMIC TESTS

- The chart lists come of the dynamic test steps for the standard
 - Each step lists timing and slewing information
 - This is a two hour test, so automation is key
- The graph shows another of the dynamic tests
 - The test slowly changes from 0 to 100 W/m² and back to 0
 - The ramp is 0.1 W/m²/s
 - This test takes 2320 seconds (38')

Table B.2 – Dynamic MPPT-Test 30 % ⇒ 100 % (valid for the evaluation of $\eta_{MPPTdyn}$)

From-to W/m ²	Delta W/m ²					Waiting time setting s	
300-1 000	700					300	
# Number	Slope W/m ² /s	Ramp UP s	Dwell time s	Ramp DN s	Dwell time s	Duration s	
10	10	70	10	70	10	1 900	
10	14	50	10	50	10	1 500	
10	20	35	10	35	10	1 200	
10	30	23	10	23	10	967	
10	50	14	10	14	10	780	
10	100	7	10	7	10	640	
						Total	6 987 s
							01:56:27 h

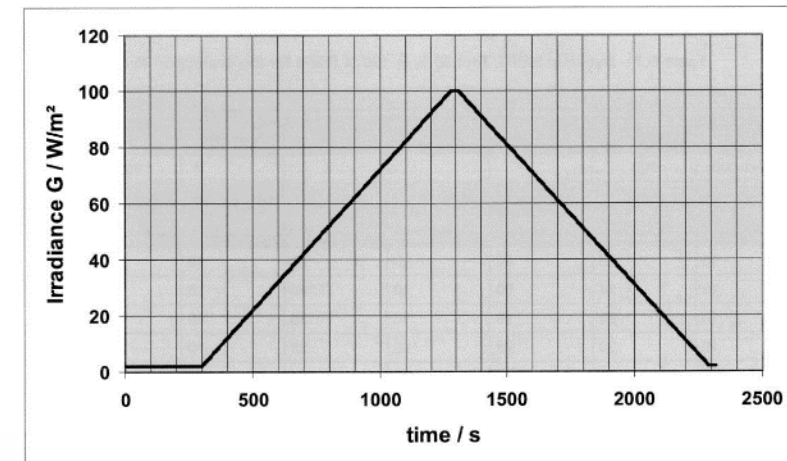
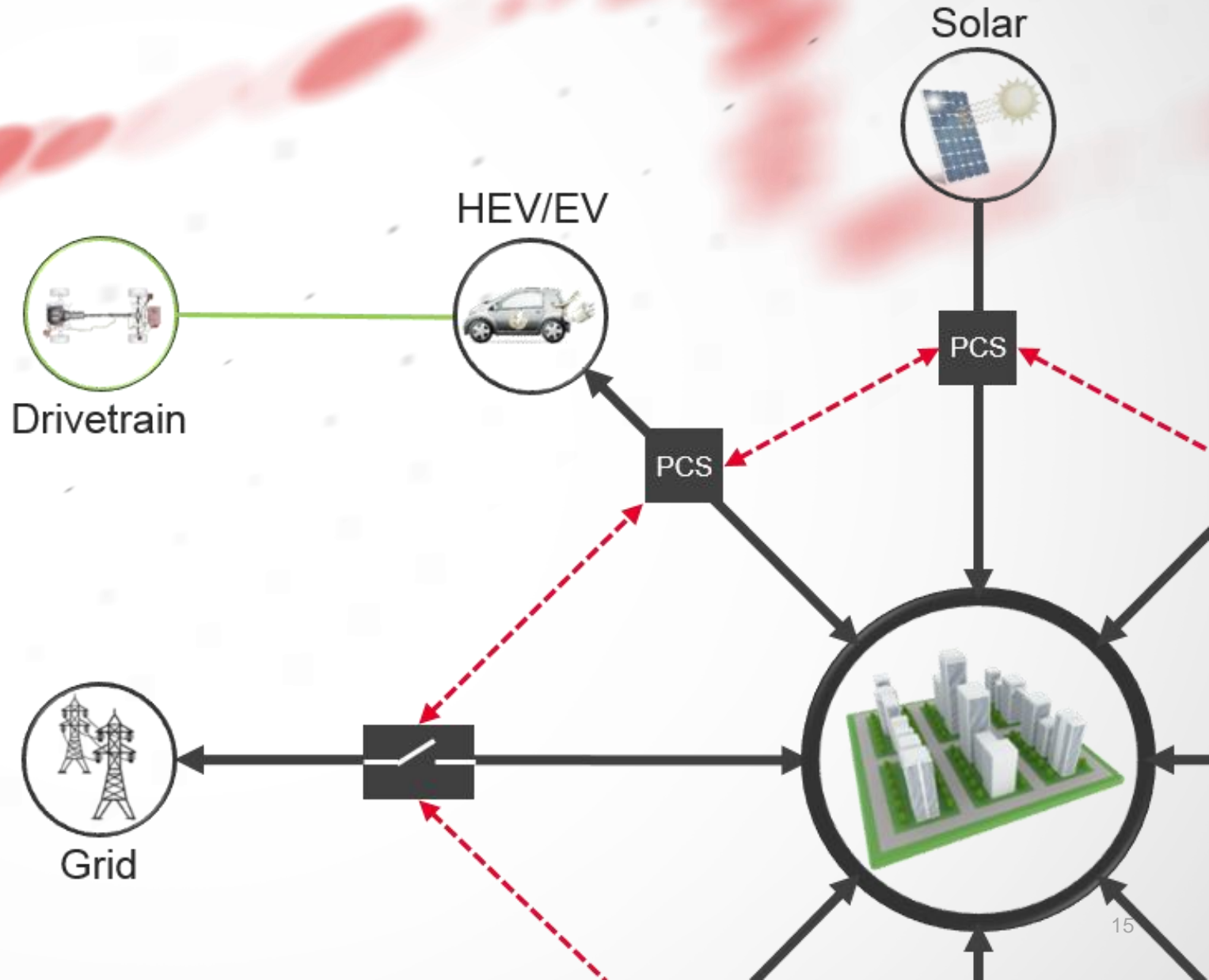

Figure B.3 – Test sequence for the start-up and shut-down test of grid connected inverters

HEV/EV & HEMS

POWER CONVERTERS



HEV/EV Power Converter Architecture

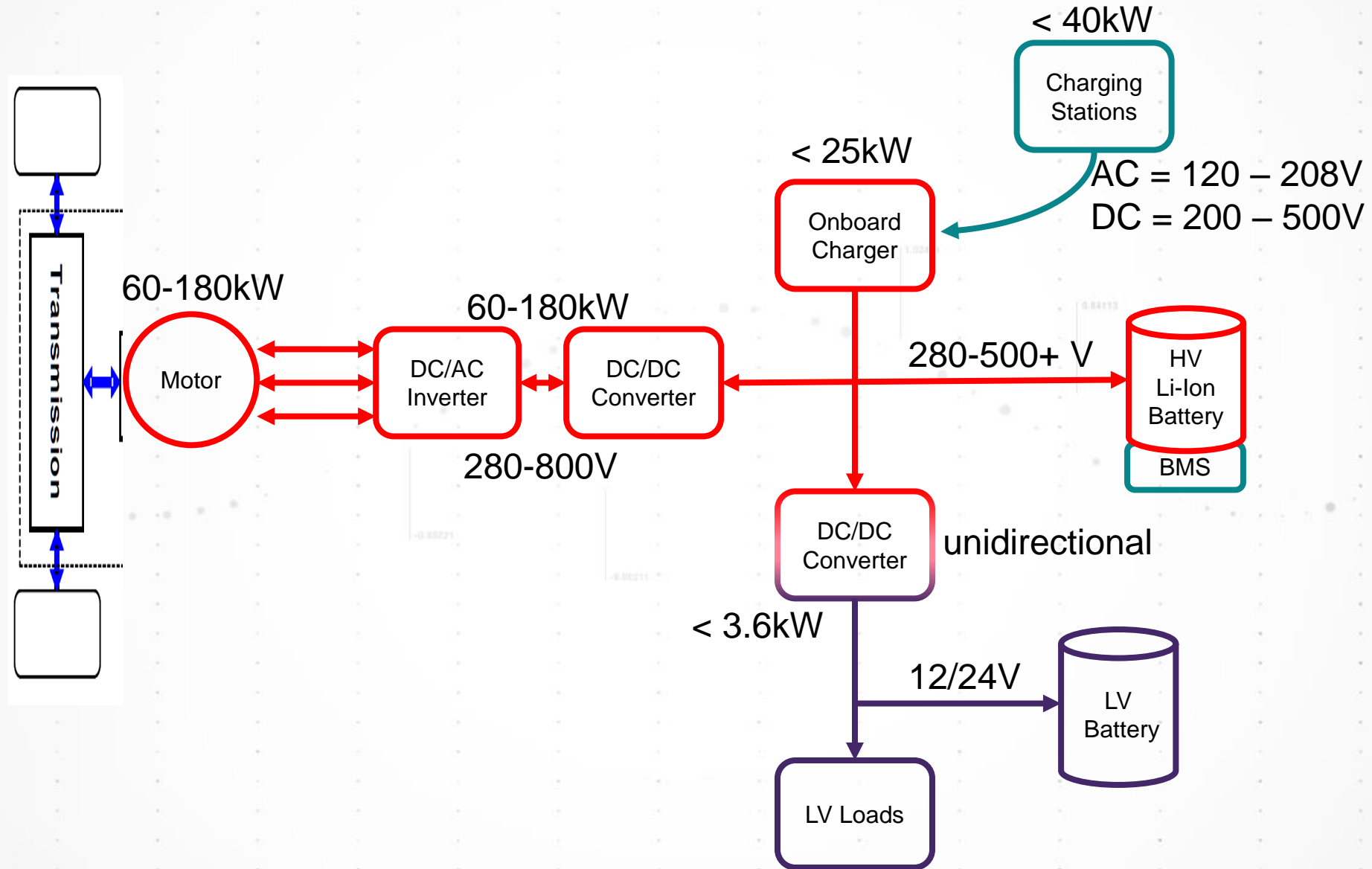

HEV/EV Power Converter Test Challenges

High Power Test System Cost

CAPEX

- Liquid Cooling required for Power Converter & Motor
- Larger Footprint
- Cost of high power instrumentation

OPEX

- Cost of power to test Power Converter
- HVAC

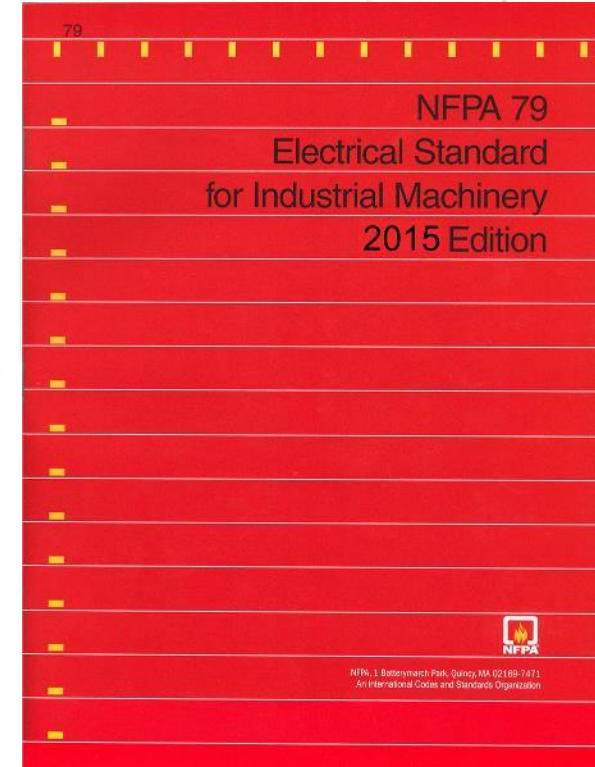
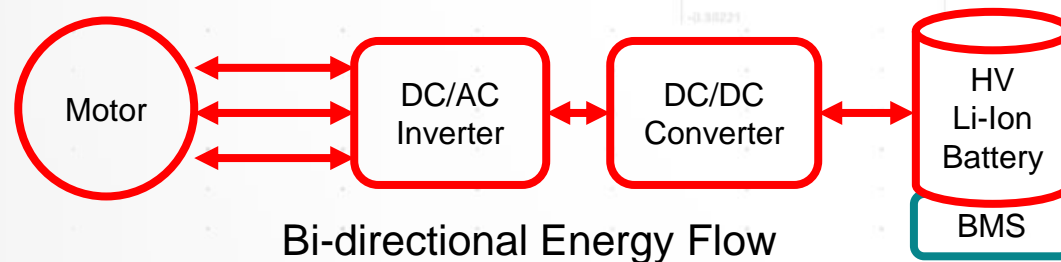

High Voltage Safety Requirements

HEMS Power Converter

A system within a home that converts one form of power into another, and viceversa from external sources

1. Sourcing power to the home from a photovoltaic array: **DC** to AC
2. Storing excess power from a photovoltaic array: **DC** to **DC**
3. Sourcing power to the home from a storage battery: **DC** to AC
4. Charging from the Grid: AC to **DC**

● = Source
● = Sink

PV Simulator Solution

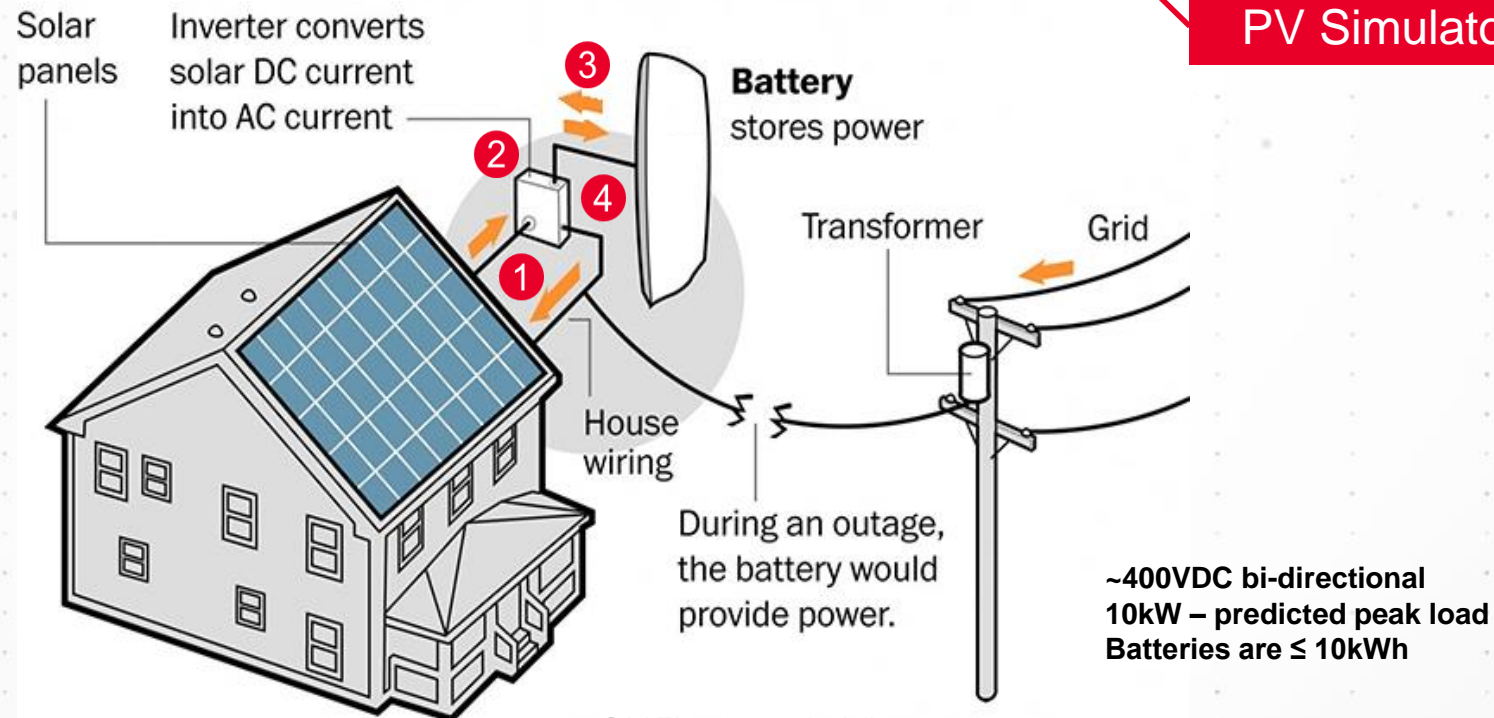

Testing the Power Converters

Requires a 2-Quadrant solution to source/sink, just like the Battery

Many existing solutions resort to traditional method of using distinct DC supplies and electronic loads:

- Complicated to implement; have to coordinate control and measurements of two instruments
- Typically has discontinuities at the transition between source & sink
- May require power supply blocking diode, which affects control and accuracy

Traditional Method:
Separate DC power supplies
and electronic loads

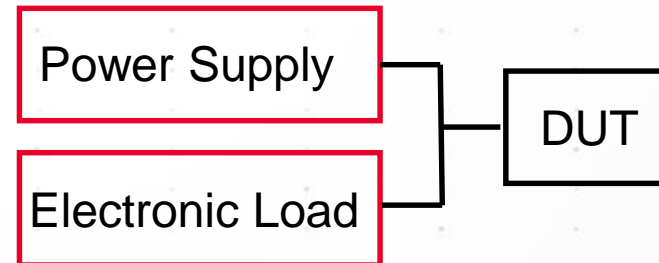

Separate Power Supply and Load for Bidirectional DUT

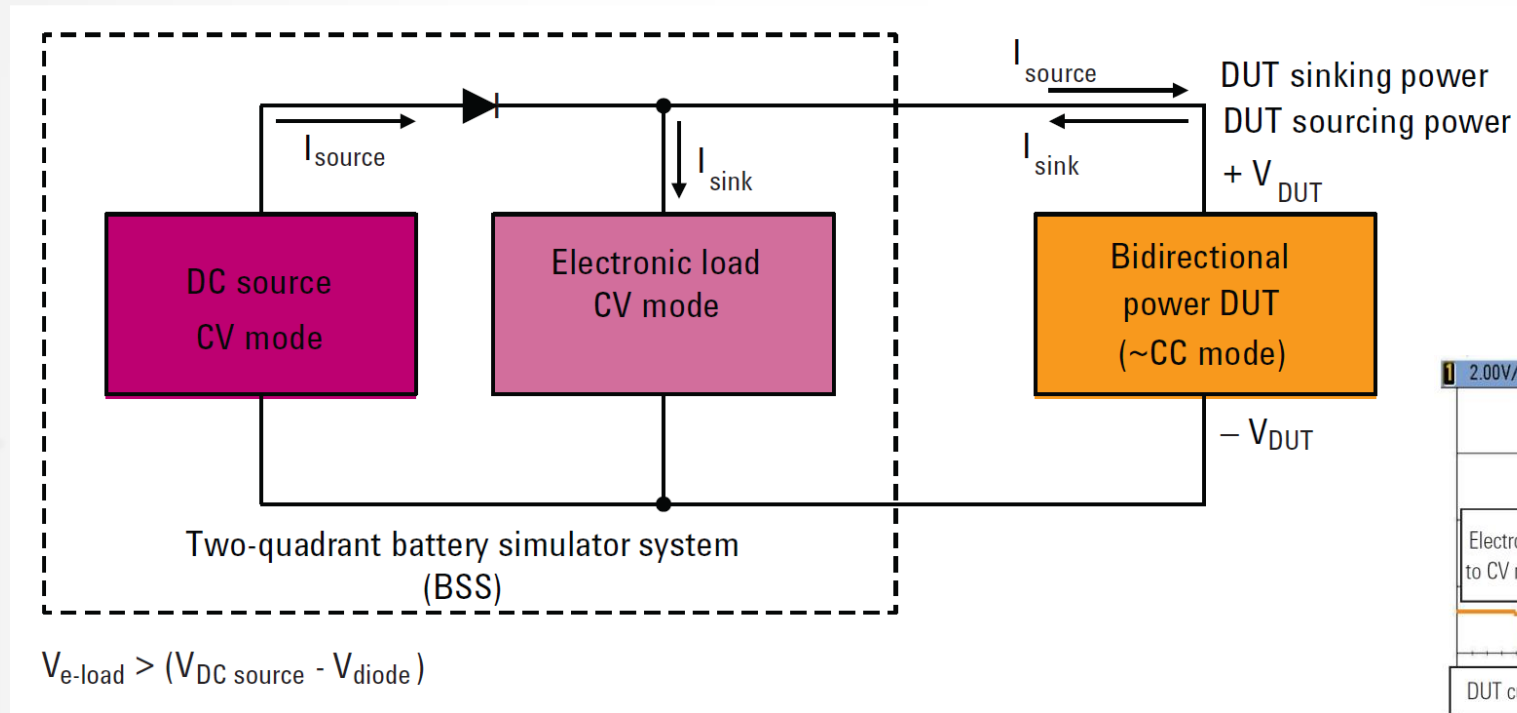

Potential 'deadband' when connecting DC source and Electronic load to test a Bi-directional DUT

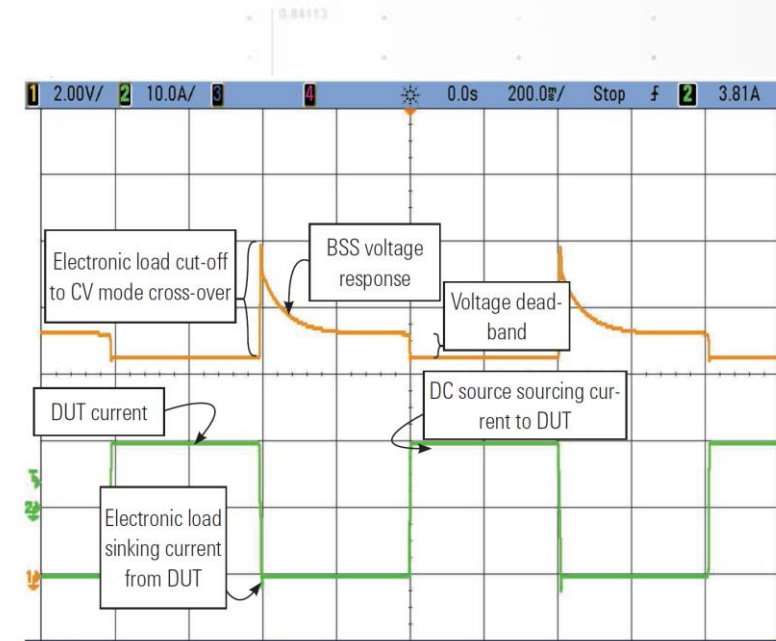
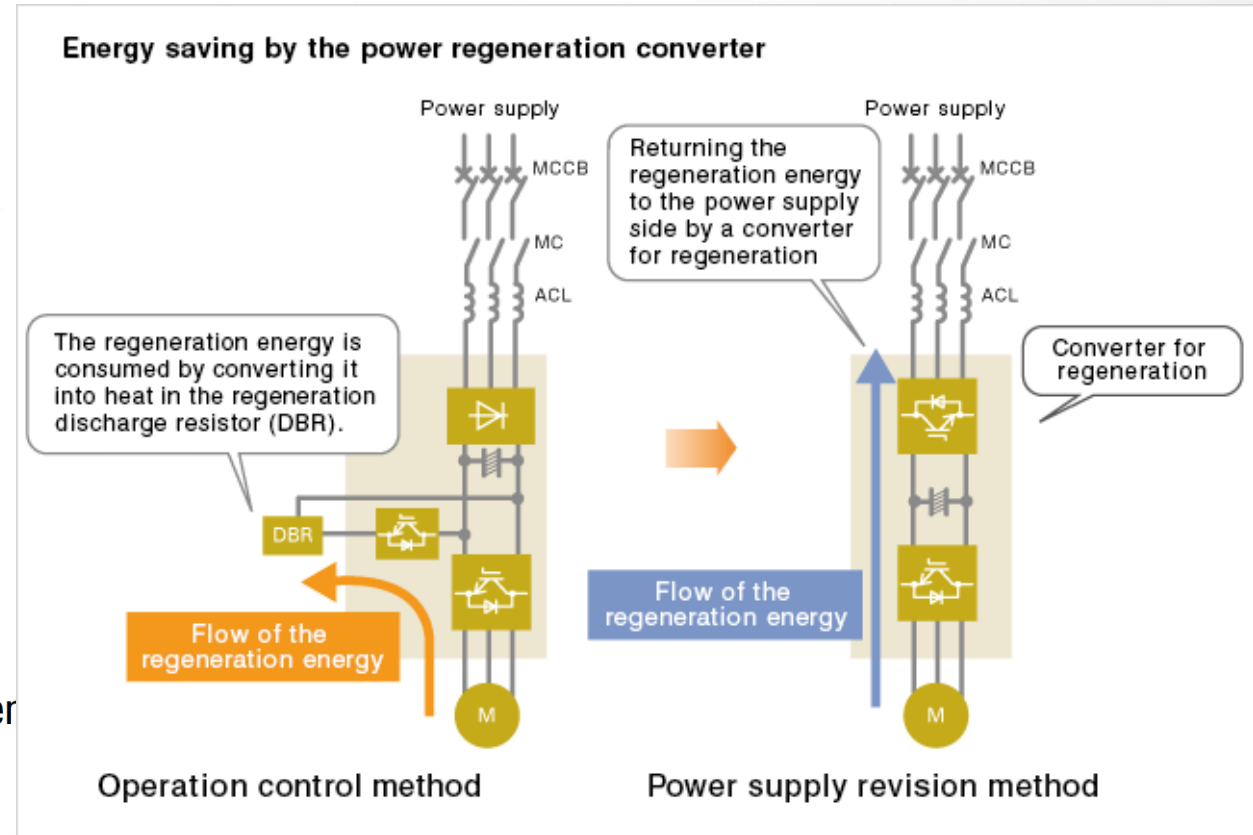
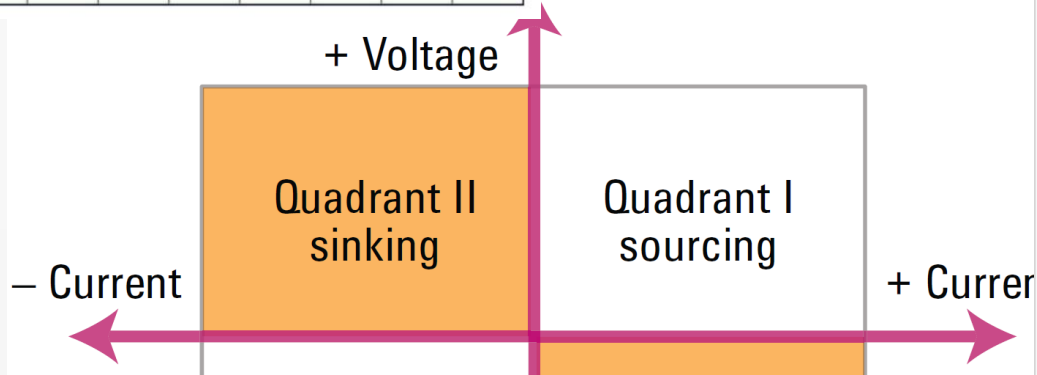
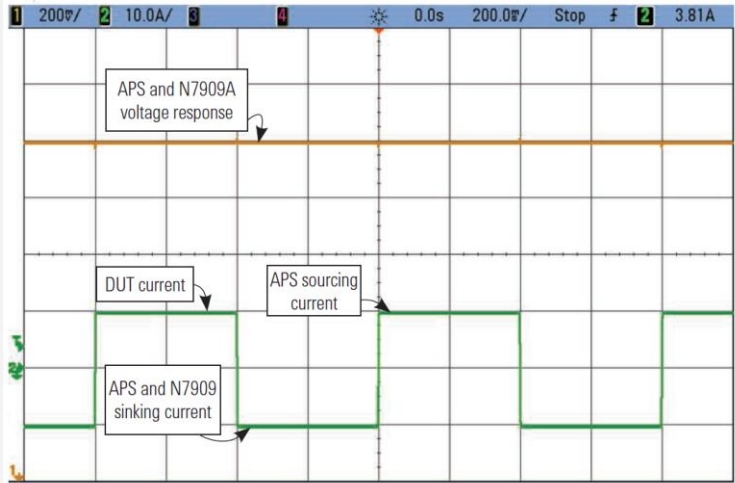

Figure 3. Source-sink transition for separate DC source and electronic load with deadband

2-Quadrant, Regenerative Power System

SEAMLESS SINK/SOURCE, SINK BACK TO THE GRID



Keysight EV1003A Power Converter Test Solution

FOR HEV/EV AND HEMS



Deliver safe and effective testing of HEV / EV and HEMS components

EV1003A Power Converter Test Solution

DELIVER SAFE AND EFFECTIVE TESTING

- Safeguard your people and your devices under test
- Handle faults and ensure output is disconnected with redundant safety disconnect system (Option SD0)
- Utilize a compact solution that serves as power source and electronic load, just like a battery
- Get sourcing and sinking up to 950V, up to 40A, and up to 10 kW
- Reduce costs for cooling and electricity with an eco-friendly design
- Count on conversion efficiency of >85% of power to the grid during regeneration



Custom Solution with 5kW and 10kW Regenerative Power

RP7900 SERIES

- 2-quadrant seamless source/sink operation
- 2-to-1 output auto-ranging for greater flexibility
- Accurate programming and measurement
- Variety of AC inputs to meet global demands

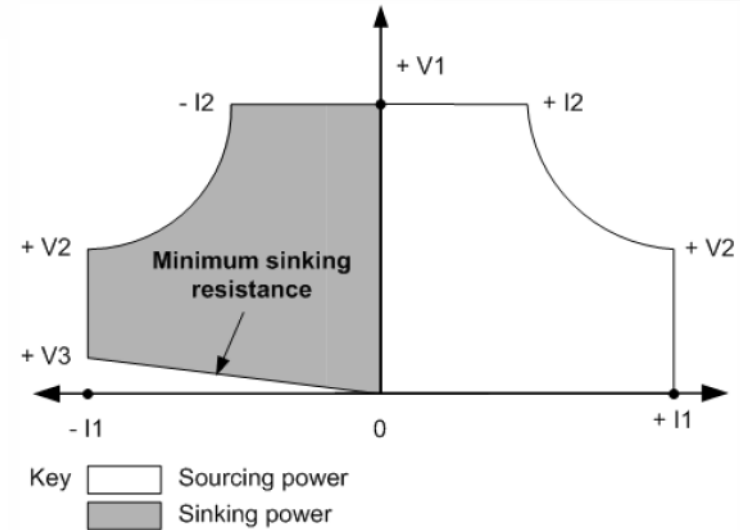

Model	+ V1	+ V2	+ V3	+/- I1	+/- I2	Minimum sink resistance
RP7951A/RP7961A	500 V	250 V	8 V	20 A	10 A	0.4 Ω
RP7952A/RP7962A	500 V	250 V	8 A	40 A	20 A	0.2 Ω
RP7953A/RP7963A	950 V	475 V	16 V	20 A	10 A	0.8 Ω

2-Quadrant Operation, like a Battery

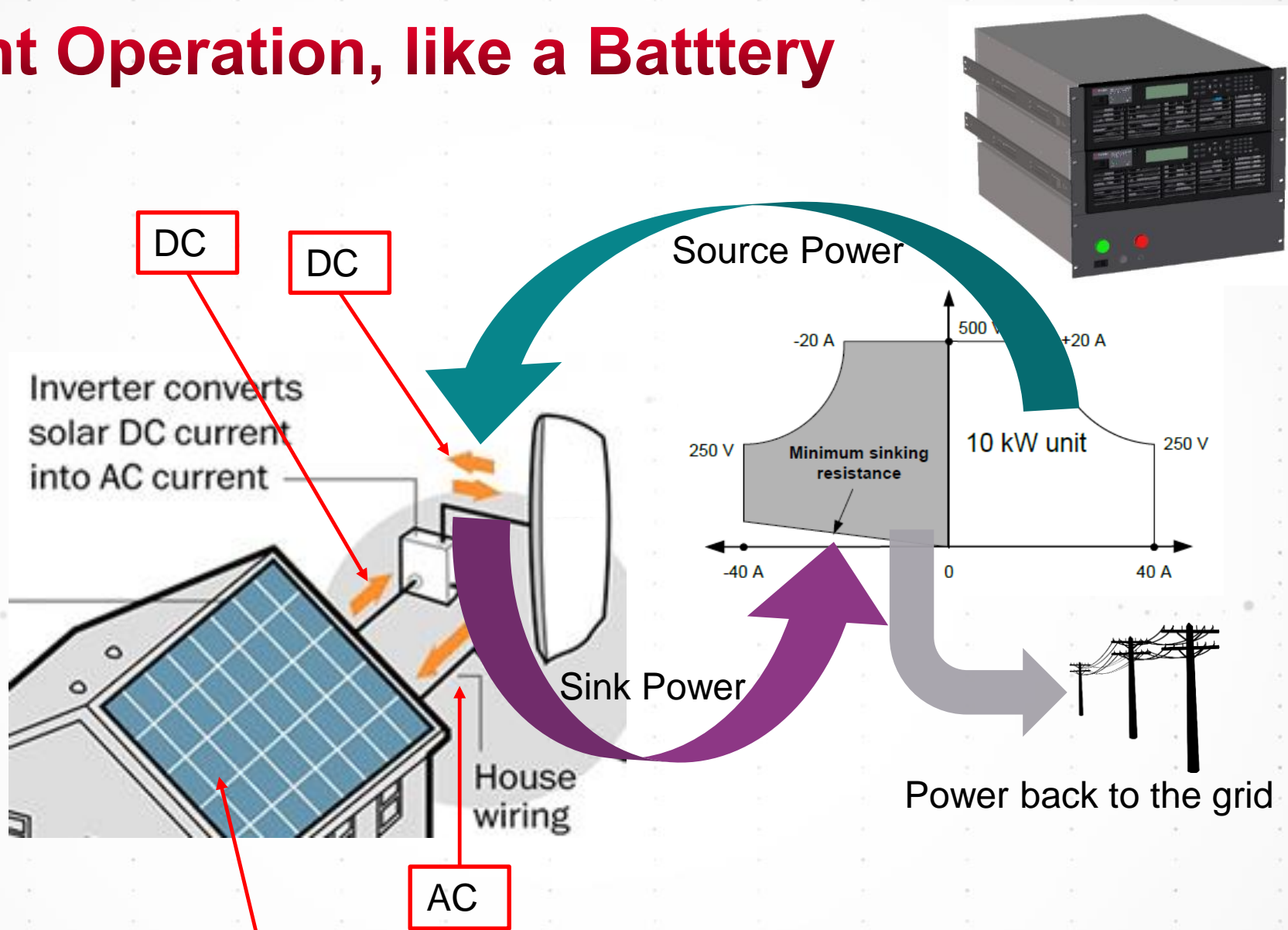

Parallel RP7900 for Higher Current



- 5 kW &/or 10 kW RP7900 in parallel with Option SD0 Safety Disconnect
- Parallel up to 15 x RP7900A for up to 150 kW

Safety Disconnect Solution (Option SD0)

SAFEGUARD YOUR PEOPLE AND YOUR DEVICES UNDER TEST

- Handle faults and ensure output is secured with redundant safety disconnect system
 - Includes four disconnection points (relays) with two each on the positive and negative sides
 - Responds rapidly by disconnecting within 15ms after a fault occurs

Rely on sensing that ensures the grid is live before generating power back to the grid (anti-islanding)



Cells

EVALUATION

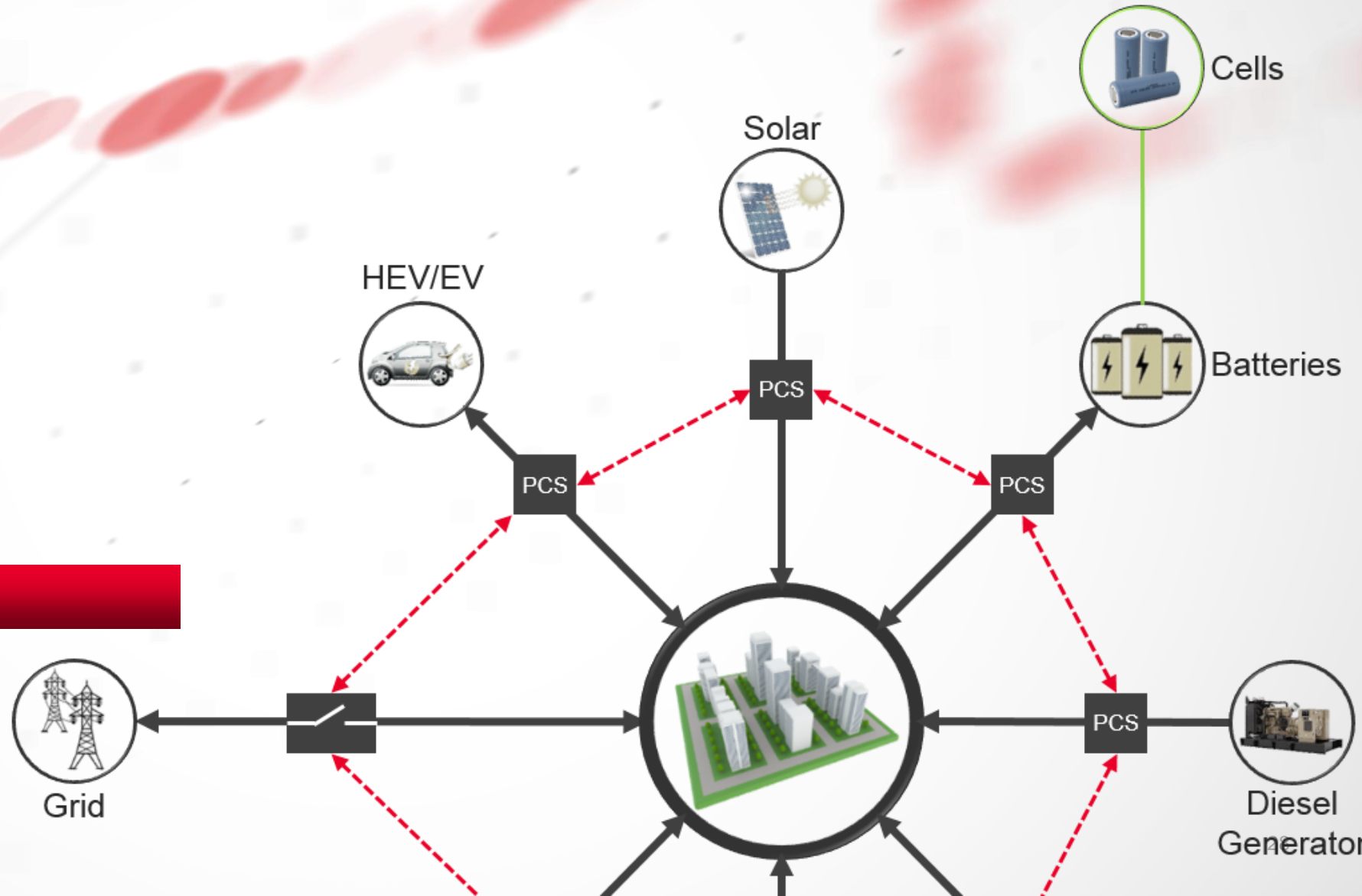

Li-Ion 101

CELLS

- Cells are the fundamental building block
- Composed of anode, cathode, and electrolyte
- Voltage of a single cell is determined by chemistry
- Capacity of a single cell is determined by chemistry and volume

Voltage of single cell is always the same, regardless of the capacity

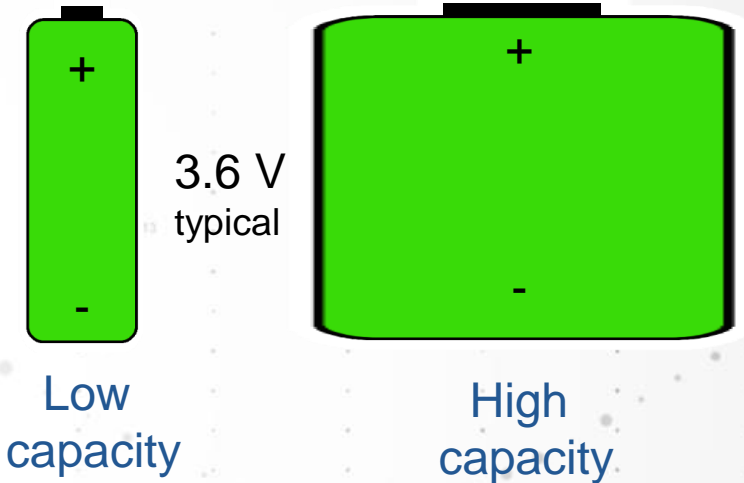

Most common:
18650 cylindrical cell



Emerging:
Large high-capacity pouch cell

Li-Ion 101

KEY MEASUREMENTS REQUIRED: CHARGE RATE

- The charge rate, C, is measured in Ah / hour = A
- 14 Ah cell charged at 1C means it is charged with current of 14 A
- 60 Ah cell discharged at 10C means it is discharged with current of 600 A

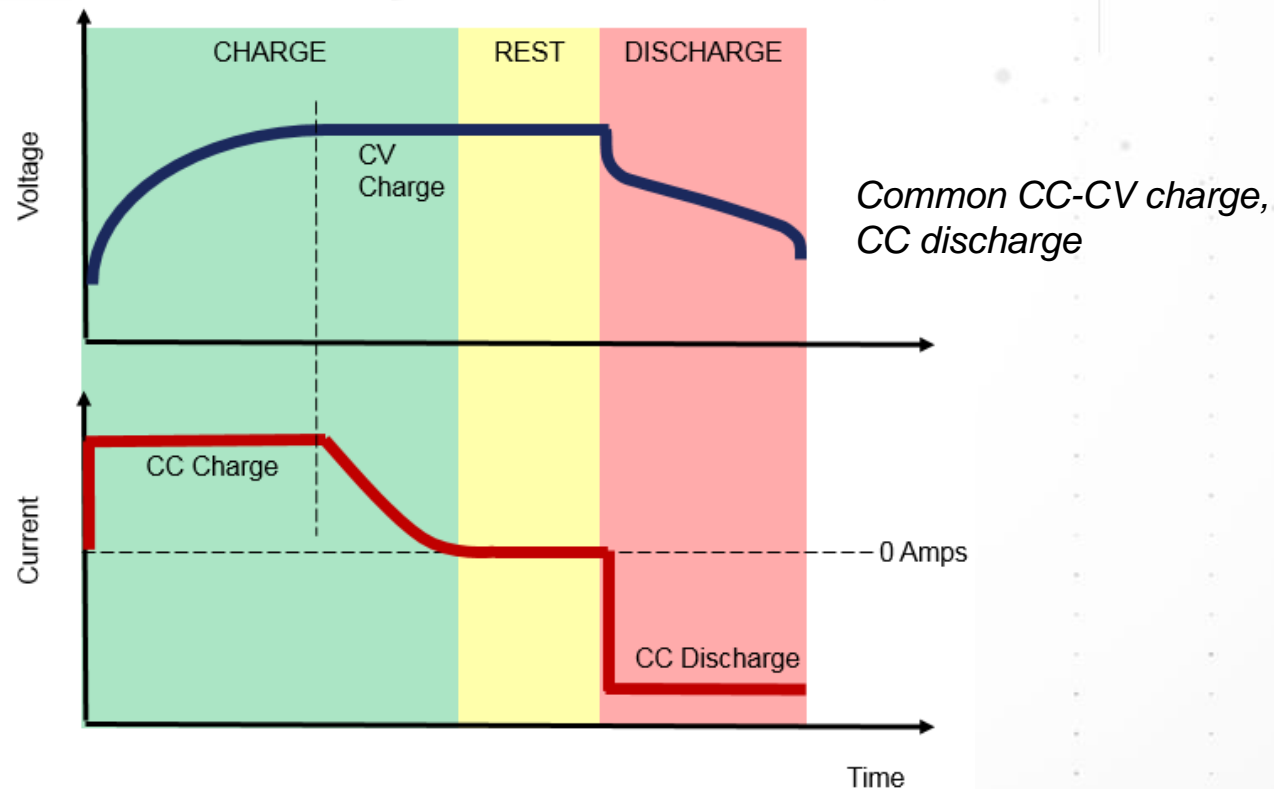

Li-Ion 101

KEY MEASUREMENTS REQUIRED: CAPACITY

- Cell voltage (OCV) is poor indicator of Li-Ion capacity or amount of charge

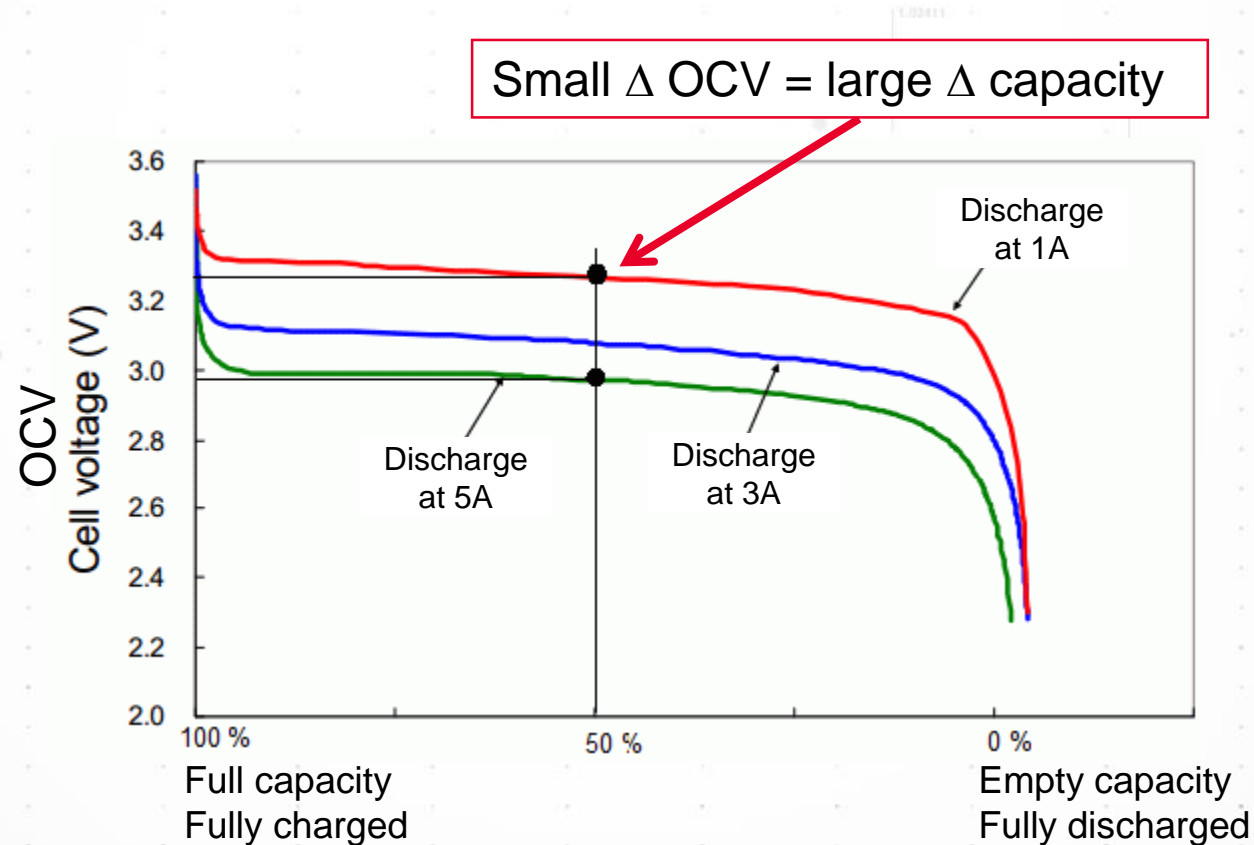

Li-Ion 101

CAPACITY MEASUREMENT

- Count coulombs: measure current and time, integrate area under curve

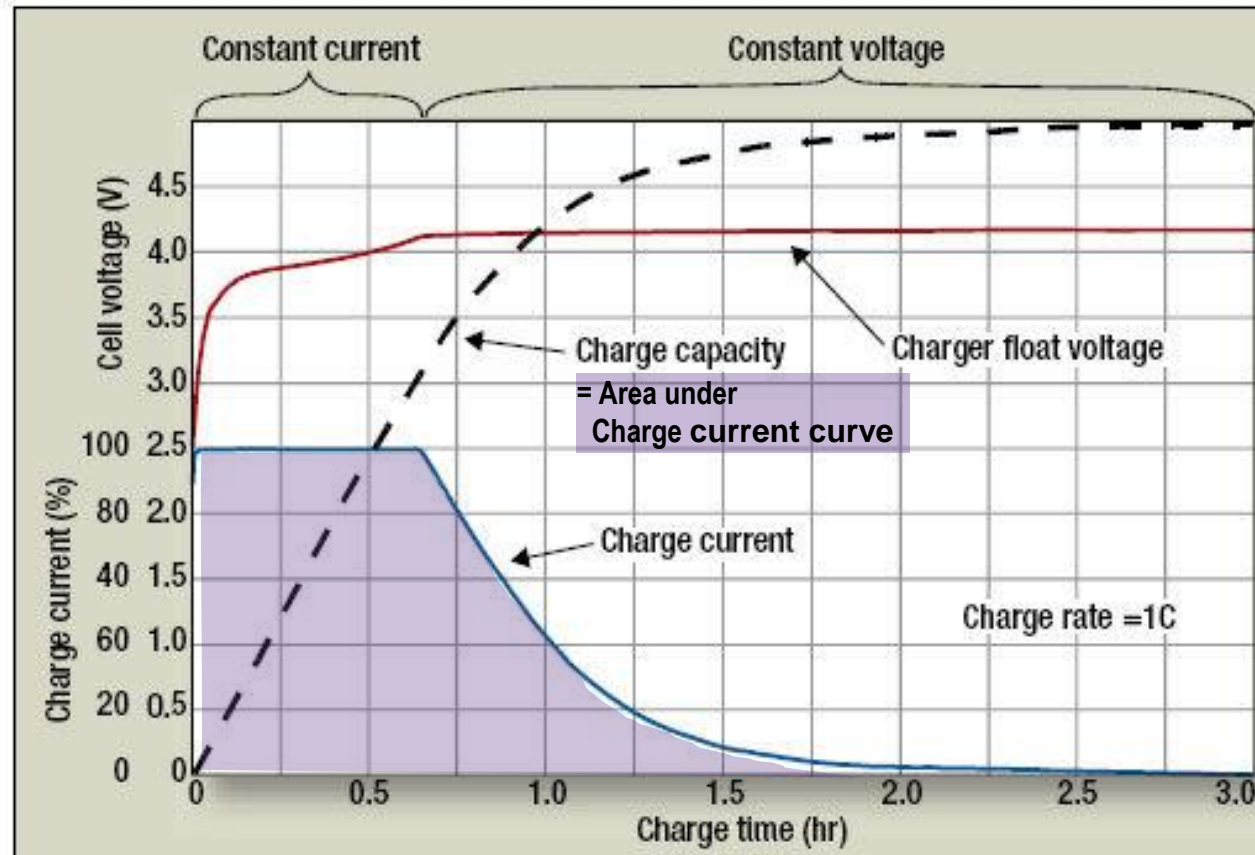

Cell Self-Discharge

- All Li-Ion cells will gradually discharge even if not connected to anything.
- Cell model: C_{eff} , R_S , and R_{SD}
- R_S , the series resistance, aka internal resistance.
 - R_S causes the cell voltage to drop as you pull more current from the cell, due to $V_{\text{cell}} = V_{\text{ocv}} - (I * R_S)$
- R_{SD} is the self-discharge resistance
 - When nothing is connected to the cell (open circuit), C_{eff} discharges through the high-value R_{SD} , generating 10's of uA of self-discharge current.
 - Over days or weeks, this self-discharge path depletes the stored energy in C_{eff} , causing V_{cell} to drop.

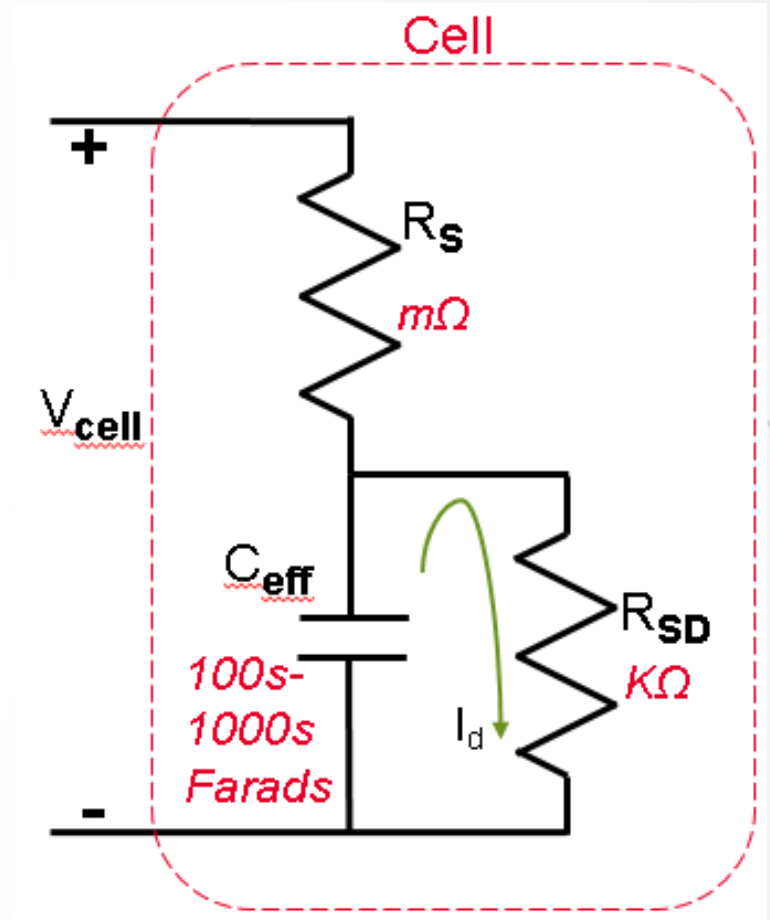

Challenges with Self-Discharge Measurement

- It is a challenge for designers & users and for manufacturers to quickly measure the self-discharge behavior of their cells.
- It's not a complicated measurement, it is relatively easy to measure how the open circuit voltage of the cells changes over time.
- The issue is **how long** it takes for that OCV to change enough to tell whether the self-discharge of the cells is acceptable or not.

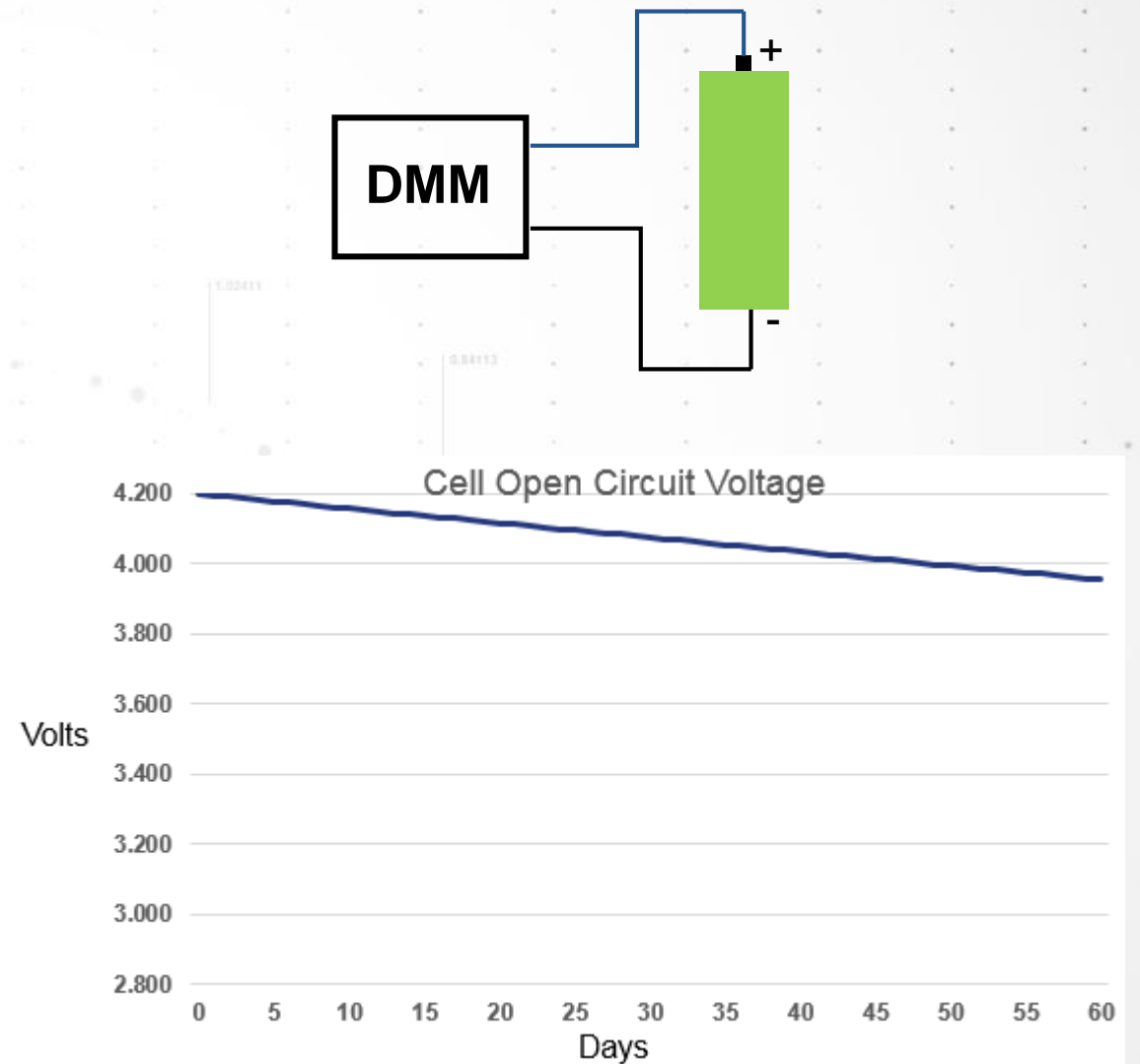

Self-Discharge is Not Just a Measurement Problem

CELL MANUFACTURERS

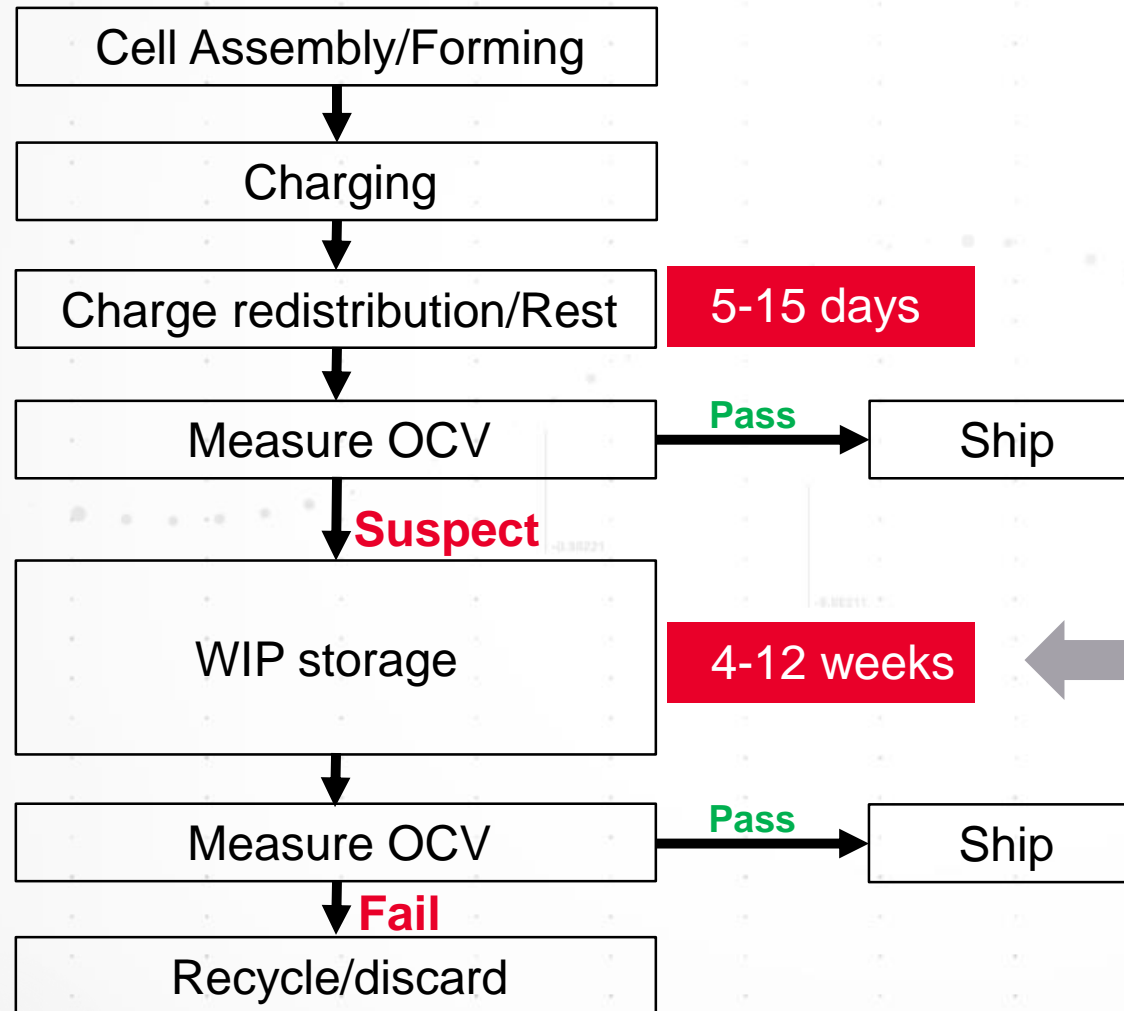

Cell manufacturers keep far greater numbers of cells in work-in-process inventory than they would like.

A New Way to Look at Self-Discharge Measurement

MEASURE OCV VS. TIME TAKES TOO LONG

- To measure 'self-discharge performance', measure the self-discharge current of the cell.
- This will tell you much sooner whether the cell is good or bad.
- The voltage applied to the cell by the test equipment must be equal to the cell voltage to avoid charging/discharging the cell.
- The voltage applied to the cell must be very stable, any instability or noise in the applied voltage will cause charge redistribution currents that will be noise on the self-discharge measurement
- Accurately measure low-level self-discharge currents in the range of 10's of μA

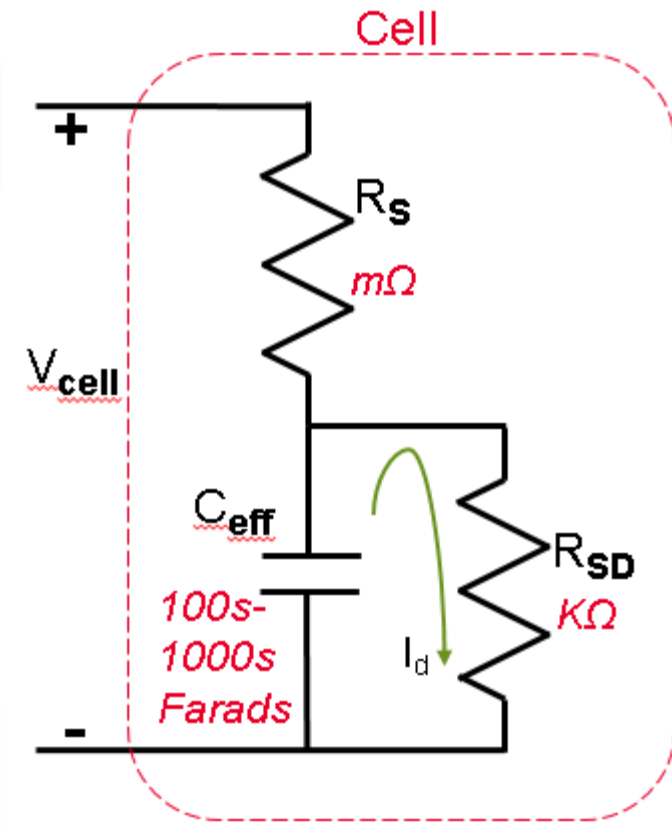

For Cell Design and Cell User Evaluation

1-CHANNEL SELF-DISCHARGE MEASUREMENT SYSTEM

- Revolutionary reduction in the time required to measure cell self-discharge current.
- System characterizes self-discharge in minutes or hours
- Software for control, graphing, logging, data storage
- **Faster evaluation results, faster design iterations**
- Eliminates weeks of storage time

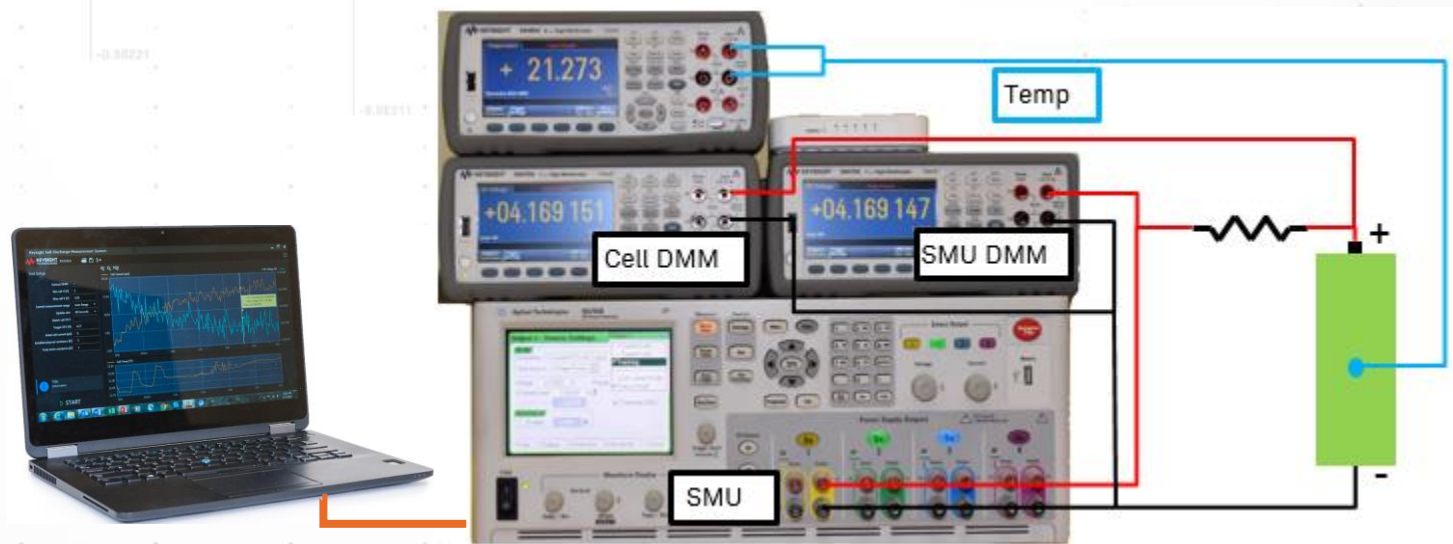
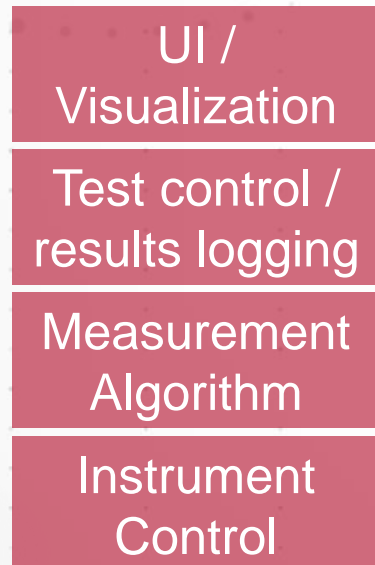

A New Solution for Self-Discharge Measurement

- Sample test results for a high-discharge 18650 cell – measured stable self-discharge current of 149 μA at ~ 1.5 hours, 159 μA at ~ 2 hours.



For Cell Manufacturing

- See a clear difference in self-discharge current for good vs. Bad cells in a few minutes, for both small and large cells.
- Much quicker than the weeks or months to measure the change in OCV over time.



*BT2152A Self-Discharge Analyzer
32 channels, 2U rack mount*

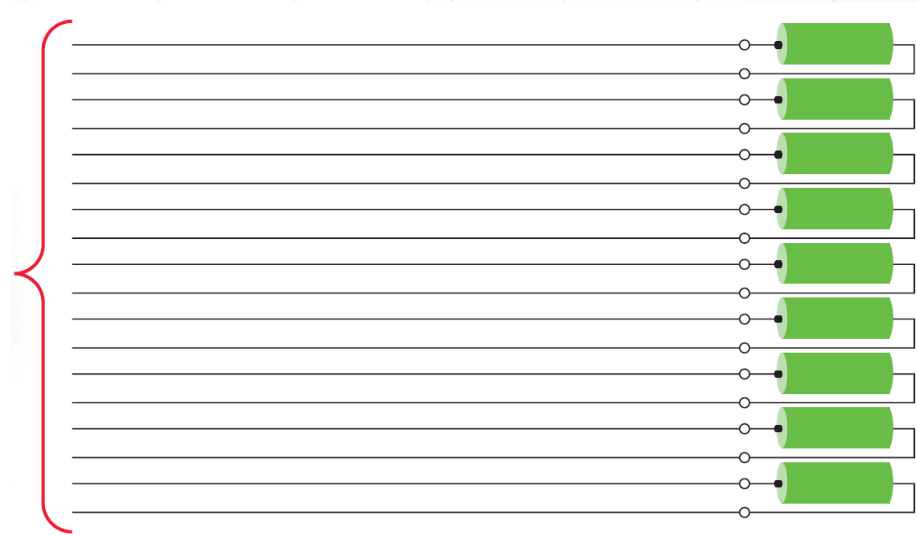

A New Solution for Self-Discharge Testing

- Tested 8x 2.5 Ah 18650 cells;
- Cell 1 forced to “bad” by connecting a 46 kΩ resistor in parallel.
- Difference between good vs. bad cells readily apparent within minutes.
- Test duration 3 hr. Self-discharge current reached 90% of final value at 1.5 hours.
- Self-discharge current for good cells ~20 uA, 100 uA for bad cell.

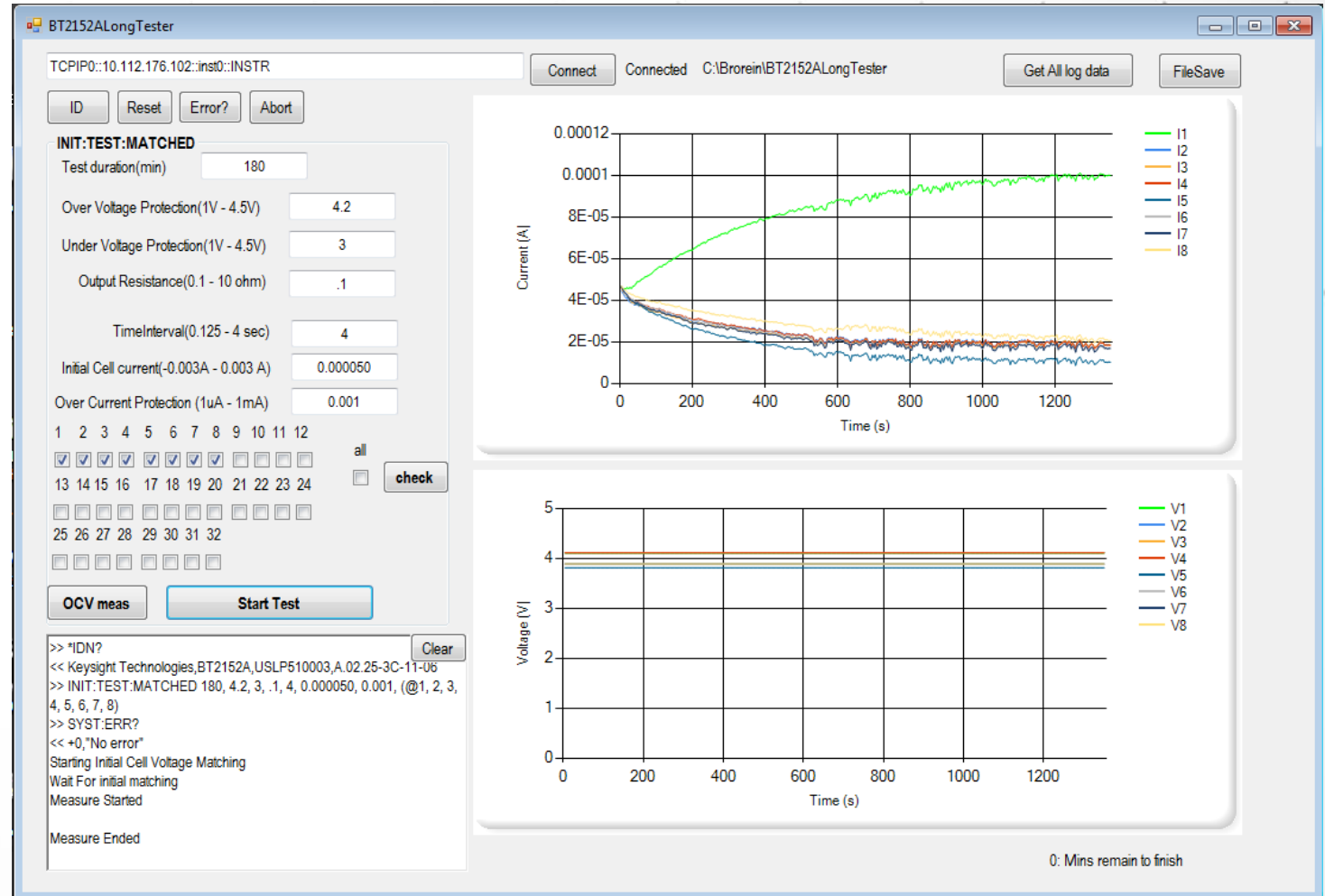

Self-Discharge Measurement Solution for Li-Ion Cells

FOR CELL DESIGN, EVALUATION, MANUFACTURING

- Provides a revolutionary reduction in time required to:
 - Measure & Analyze self-discharge current in design
 - Discern good vs. bad cell self-discharge performance in manufacturing

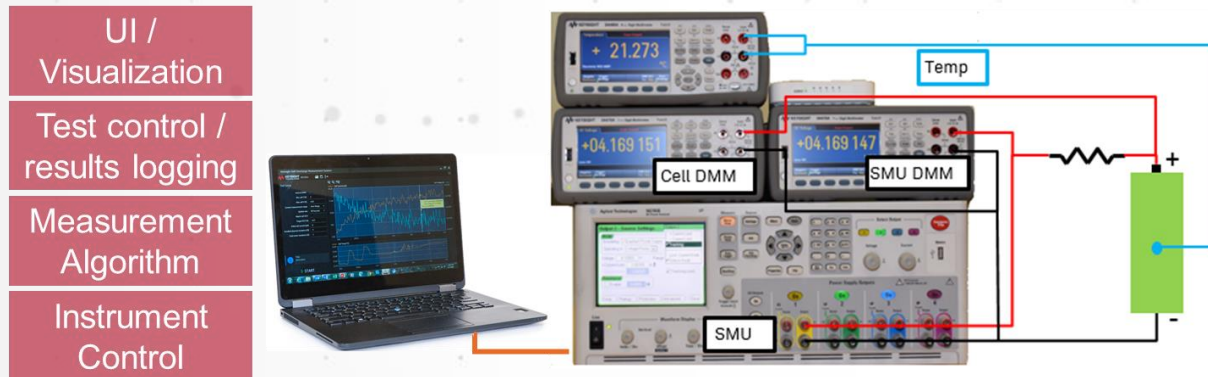

BT2191A Self-Discharge Measurement System
Control/Analysis software, 1 channel



BT2152A Self-Discharge Analyzer
32 channels, 2U rack mount

The Smart Grid

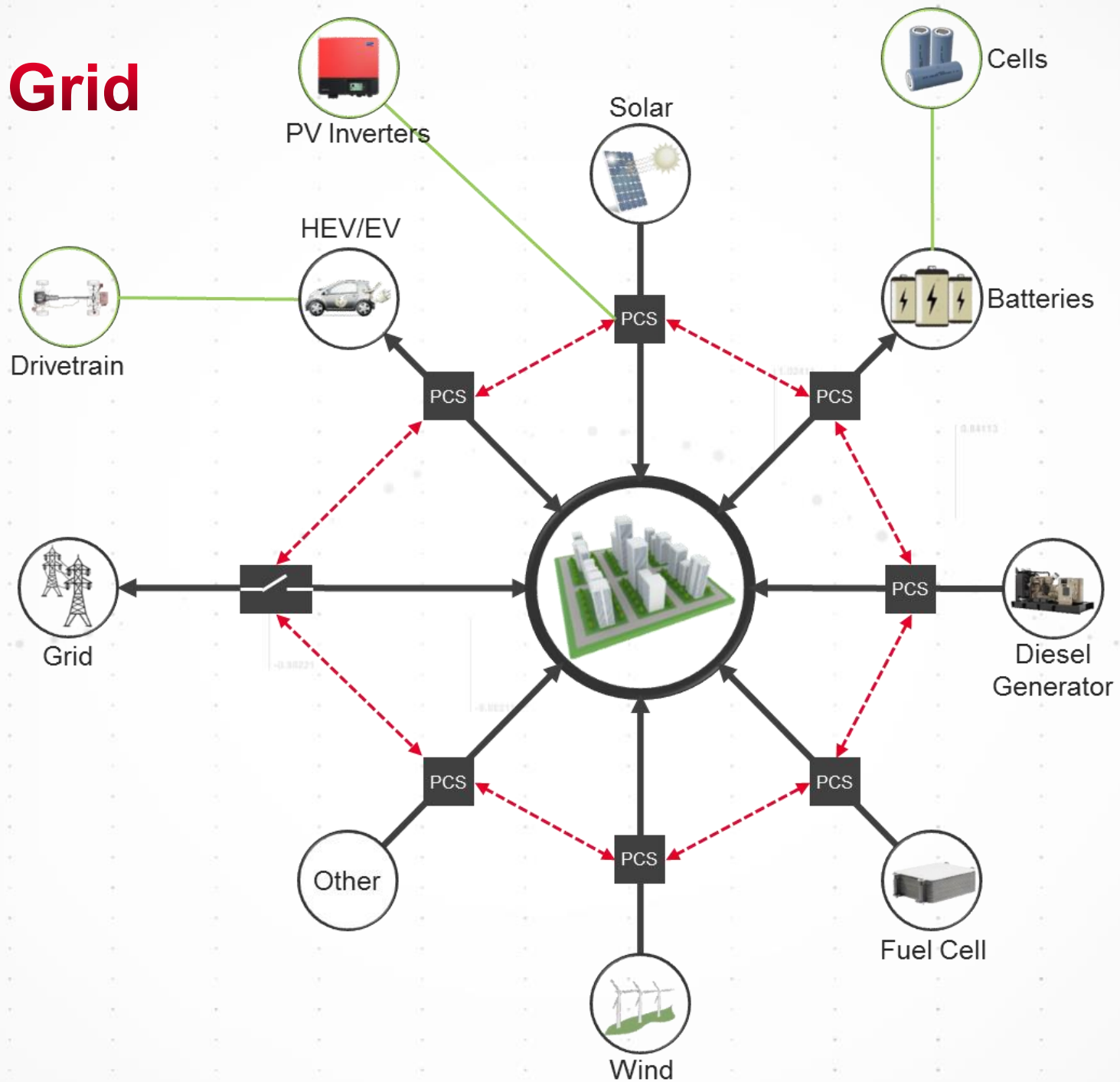

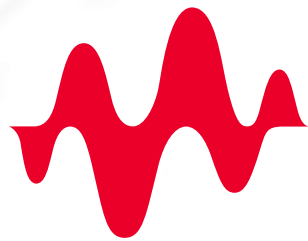

KEYSIGHT
TECHNOLOGIES

4.50221